



**THE EXHIBITORS'
HAND
BOOK**

MODULAR DISPLAY SOLUTIONS

BANNER STANDS | RETRACTABLE 1-5

BANNER STANDS | TENSION POLE & TELESCOPIC..... 6-7

OUTDOOR PRODUCTS 8-11

DFA | ECONOMY DISPLAY PRODUCTS 12-14

BACKWALLS & INFO CENTERS 15

HOPUP | TENSION FABRIC 16-17

POPOP DISPLAY SYSTEMS | CASES 18-22

FORMULATE | EXHIBIT BOOTHS 23-26

FORMULATE | HANGING STRUCTURES 27-29

TABLE THROWS AND RUNNERS 30-31

FOLDING DISPLAY PANELS 32-35

COUNTERS & KIOSKS 36-38

VECTOR WALL FRAMES 39

LINEAR DISPLAY SYSTEMS 40-45

ORBITAL EXPRESS TRUSS 46-61

LITERATURE RACKS 62

LUMINOSITY | DISPLAY LIGHTING 63

CASES 64

DISPLAY ADDITIONS 65

SYMBOLS USED IN THE EXHIBITORS' HANDBOOK:



premium product



product can be recycled
(does not include graphic application)



product is made in the U.S.



affordable product



new addition to
The Exhibitors' Handbook



economy product



product comes with a carry
bag or case

WARRANTY KEY:



lifetime warranty
(hardware)



90 day warranty
(hardware)



5 year warranty
(hardware)



graphics limited
1 year warranty



1 year warranty
(hardware)



graphics limited
6 month warranty



ORCHID

33.5"
WIDE

ORCHID



- quick to assemble and easy to use
- bamboo base, rail and pole are a sustainable choice
- slide graphic rail
- includes carry bag





IMAGINE

31.5" WIDE IMG

- variable height= 29.5"- 83.35"
- graphic tensioner
- anti-slip strips along base
- integrated pole storage
- telescopic pole
- interchangeable graphic cassette



BARRACUDA

31.5" WIDE BCD

- variable height= 29.5"- 83.35"
- graphic tensioner
- integrated pole storage
- telescopic pole



EXCALIBUR

31.5" WIDE EXC

- variable height= 29.5"- 83.35"
- double sided
- graphic tensioner
- integrated pole storage
- telescopic pole

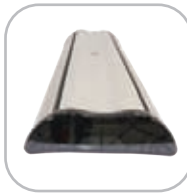

ADVANCE

31.5" WIDE ADV

- variable height= 29.5"- 83.35"
- double sided
- graphic tensioner
- anti-slip strips along base
- integrated pole storage
- interchangeable graphic cassette
- telescopic pole



ORIENT

31.5" WIDE silver: ONT-800-S
black: ONT-800-B

35.5" WIDE silver: ONT-920-S
black: ONT-920-B

39.25" WIDE silver: ONT-1000-S
black: ONT-1000-B

- standard height= 83.25"
- anodized silver or black
- molded end plates
- 3-piece bungee corded pole

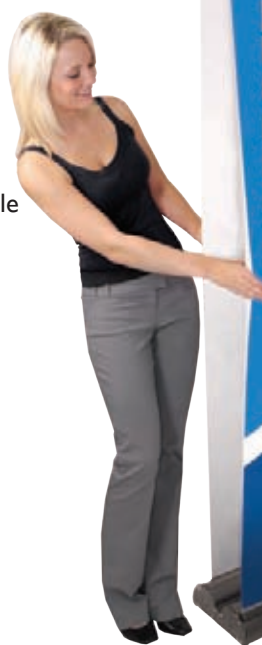
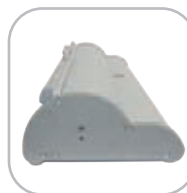

ORIENT 2

31.5" WIDE silver: ONT-800-DBL-S
black: ONT-800-DBL-B

35.5" WIDE silver: ONT-920-DBL-S
black: ONT-920-DBL-B

39.25" WIDE silver: ONT-1000-DBL-S
black: ONT-1000-DBL-B

- standard height= 83.25"
- double-sided
- anodized silver or black
- molded end plates
- 3-piece bungee corded pole



BLADE LX

33.5" WIDE BLD-LX-GRY

- standard height= 83.25"
- features a gunmetal anodized body & cast chrome end plates
- roller access via flip-top lid & removable self-locking graphic roller mechanism
- quick change graphic slider
- adjustable feet on base are useful on uneven floors
- 3-piece bungee corded pole & premium top rail



CONTENDER

23.5" WIDE silver: CN-24-S
black: CN-24-B

29.5" WIDE silver: CN-30-S
black: CN-30-B

35.5" WIDE silver: CN-36-S
black: CN-36-B

47.5" WIDE black: CN-48-B

- standard height= 77.5" or 105" high with optional 4th pole
- swivel-out foot
- powder coated silver or black finish
- laser cut steel ends & swaged pole
- made in the U.S.A.





ELEVATE

31.5" WIDE ELEVATE **NEW**

- over 8' tall
- telescopic pole (4 piece)
- roller access via flip-top lid and removable self-locking graphic roller mechanism
- variable height 32" – 96"
- black aluminum body with chrome endcaps





PACIFIC

31.5" WIDE PAC-800-S

35.5" WIDE PAC-920-S

39.25" WIDE PAC-1000-S

- standard height= 83.75"
- anodized silver
- molded end plates
- swivel-out foot
- 3-piece bungee corded pole



BLOK

33.5" WIDE BLOK **NEW**

- attractive black base with chrome endcaps
- includes carry bag
- bungee pole
- quick and easy to assemble

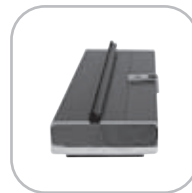



LIGHTNING

31" WIDE LTNG

- standard height= 77"
- snap-lock graphic rails
- 3-piece bungee corded pole



DASH LITERATURE POCKET

31.5" WIDE DSH-M-LR

- recommended graphic height= 44"
- separate 3 pocket literature dispenser option to attach to a Dash unit



DASH MEGA 1 & 2

36" WIDE single sided: DSH-ME double sided: DSH-ME-2

- variable height= up to 93.5"
- stable, anodized aluminum
- quick & easy to erect



DASH 1 & 2

31.5" WIDE single sided: DSH-M-1 double sided: DSH-M-2

- variable height= up to 78.5"
- stable, anodized aluminum
- quick & easy to erect



PEGASUS

52.5"-95" WIDE silver: PGSUS-S black: PGSUS-B

PEGASUS MINI

27.5"-48" WIDE silver: PGSUS-MIN-S black: PGSUS-MIN-B

- both feature variable height= 36.5"- 96"
- backwall or backdrop
- single or double sided
- dual telescopic poles

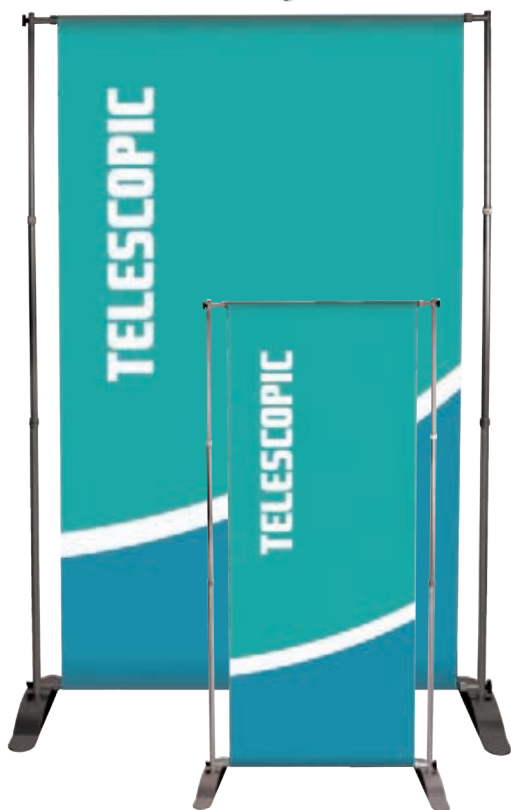

UNO

31.5" WIDE UN-I-ST

36" WIDE UN-I-MG

48" WIDE UN-I-MO

- variable height= 35"- 85.5"
- powder coated black weighted base



WIND DANCER LT

31.5" WIDE WIND-LT

- adjustable height= up to 13'6"
- hollow base can be filled with either water or sand as weighing agent
- easy to position, erect, and remove



WIND DANCER

43" WIDE WIND-MX



- adjustable height= up to 17'3"
- flag is approximately 3'6" wide
- hollow base can be filled with either water or sand as weighing agent
- easy to position, erect, and remove



BLAST

19'8" TALL BLST

- display a single flag or as many as 5
- bungee corded poles fabricated from hybrid aluminum/steel
- powder coated steel base
- comes with 4 ground spikes & rubber mallet



WIND DANCER SPIRE

16' TALL WIND-MX-FPCK2

- adjustable height= up to 17'3" tall
- allows a standard Wind Dancer or Wind Dancer LT to be converted to a double-sided "V" shape banner
- Wind Dancer Spire conversion is not intended for outdoor use



Wind Dancer Lanyard allows a standard Wind Dancer or Wind Dancer LT to be converted into a flagpole
WND-MX-FPCK



SPINNAKER

8'7" TALL SPKR

- portable outdoor billboard
- maximum graphic area of 8'w x 8'h (weather & wind conditions permitting)
- single or double sided
- units can be linked together for added impact



BLIZZARD

BLZD

- adjustable width= up to 40"
- adjustable height= up to 80"
- base can be filled with water or sand
- easy grommet graphic attachment



MONSOON

MONSN-2



- semi-portable single or double sided billboard
- strong frame is quick & easy to assemble
- includes ground stakes & bungee rope
- banner & grommets not included



ROCKET



- 3 legs can be filled with water or sand
- single or double sided
- spring-loaded graphic support 1/8" coroplast plastic or similar substrate recommended
- ideal for contour cut custom graphics
- graphic size may vary



ZOOM



- can be used indoors or out
- graphic rotates in wind
- water fillable donut adds stability
- graphic printed on flag material
- double sided graphic is available
- both floor base & ground stake included (additional base options available, see page 10)
- additional sizes & shapes available on page 10

BRUTE

BRUTE



- use one to hold a smaller graphic, or as many as you need to hold a large graphic
- secure grip allows for use outdoors in the elements as well as inside
- quick set-up, easy storage
- fill with water or sand, 100% empties after use
- works with a variety of graphic substrates



contoured base sits stable on uneven terrain



recommended width: 1 Brute per 4' of signage

WHIRLWIND

WHRL-WND



- front-loading snap frames constructed from aluminum & powder-coated steel
- single or double sided
- includes clear lens cover
- quick & easy graphic changes
- dual-spring design flexes to withstand wind gusts
- compact durable base can be filled with water or sand for extra stability
- integrated wheel set



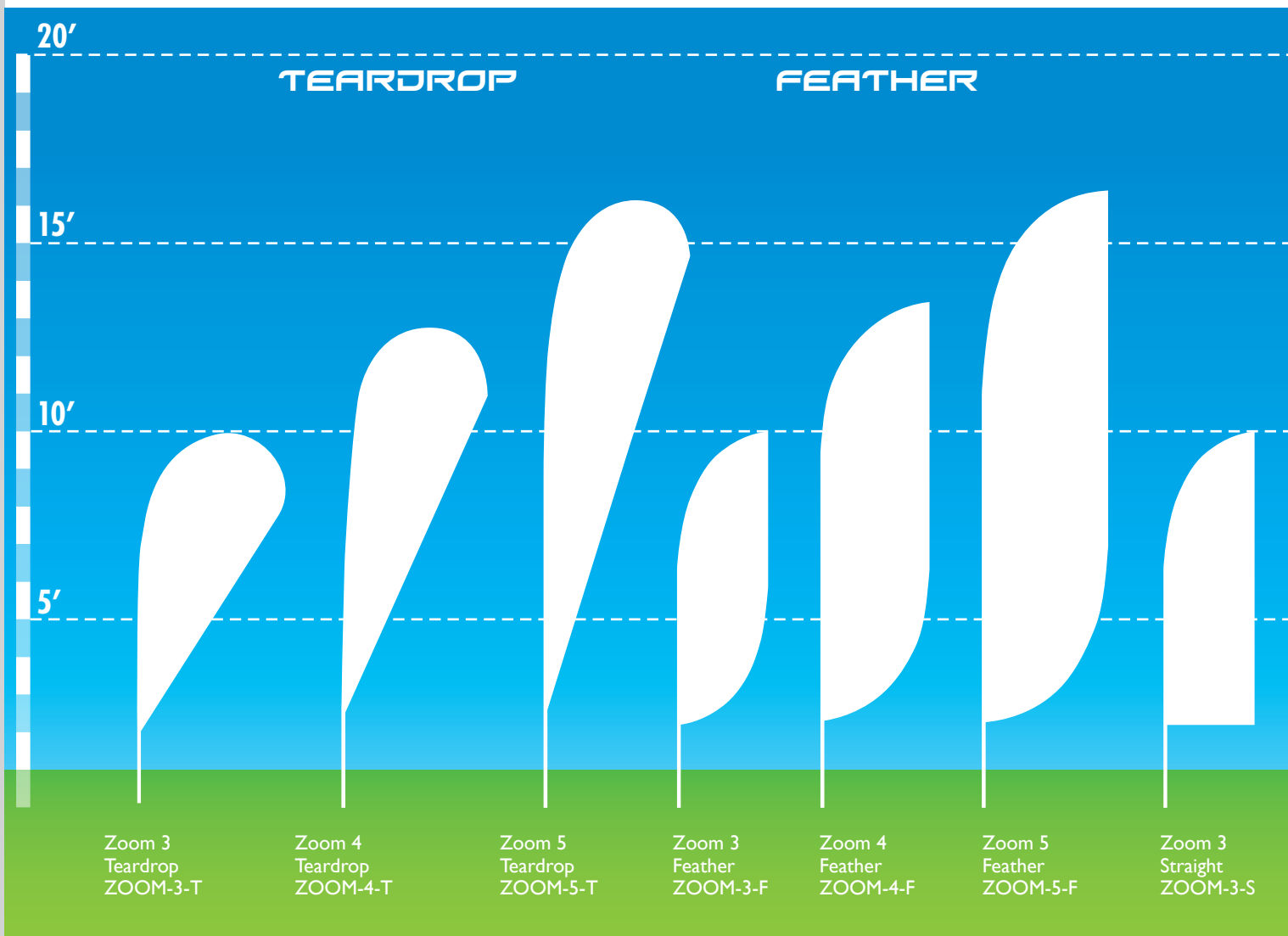

ZOOM LINE

- can be used indoors or out
- graphic rotates in wind
- water fillable donut adds stability
- graphic printed on flag material
- double sided graphic is available
- both floor base & ground stake included
- 3 shapes and 3 sizes available



Zoom hardware & bag set



ground stake (included)

for use in sand or other hard-to-stake ground



auger base (ZOOM-AUG)



drive-over base (ZOOM-VEHICLE)

designed to be positioned under vehicle tire



STRAIGHT

WIND DANCER

BLAST

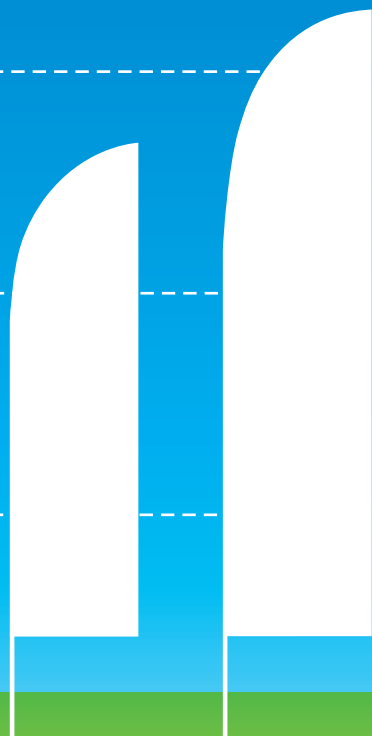

Zoom 4
Straight
ZOOM-4-S

Zoom 5
Straight
ZOOM-5-S

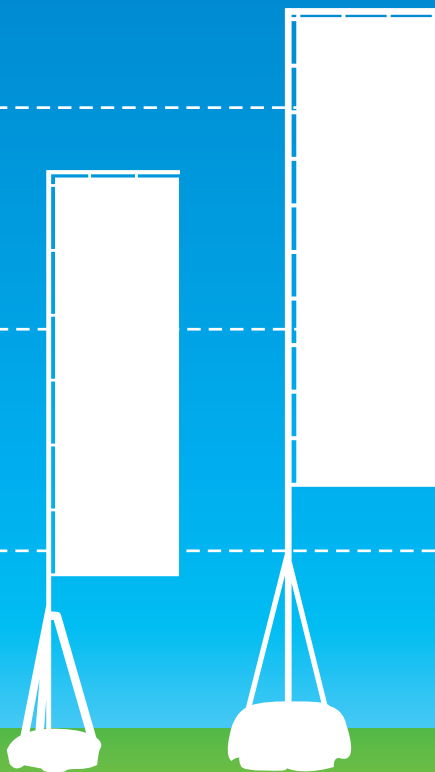

Wind Dancer LT
WIND-LT

Wind Dancer
WIND-MX

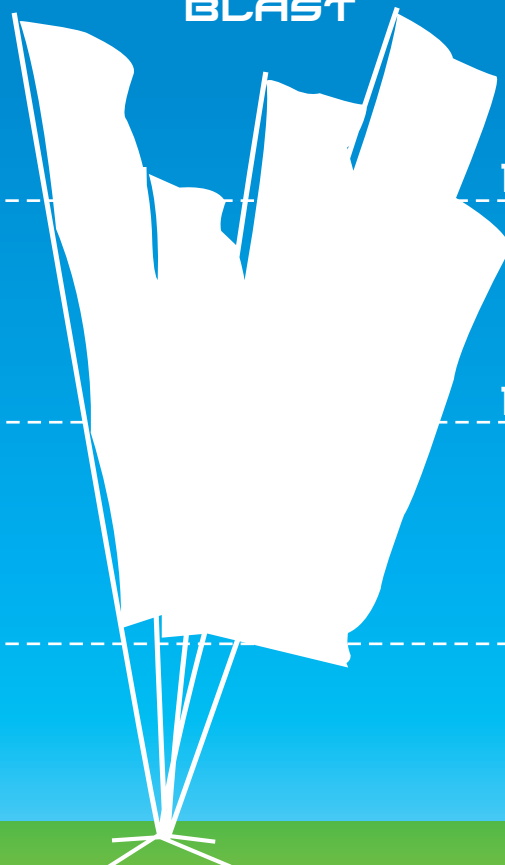

Blast
BLST



WIND DANCER

- Wind Dancer LT= up to 13'6"
- Wind Dancer= up to 17'3"
- hollow base can be filled with either water or sand as weighing agent
- easy to position, erect, and remove



Wind Dancer bag set available
(WIND-MX-BGSET)



BLAST

- display a single flag or as many as 5
- bungee corded poles fabricated from hybrid aluminum/steel
- powder coated steel base
- comes with 4 groundspikes & rubber mallet



DFA (Direct from Asia) is our range of super economy banner stands & display solutions. Unlike most of our other products which are designed and developed by our team of display specialists in the U.S.A., the DFA range of indoor and outdoor products represents the best choices from a selection of independent display producers located across the length and breadth of Asia.



RETRACTOR 2

31" WIDE RTRC-2

- standard height= 77.5"



RETRACTOR 4

32.75" WIDE RTRC-4

- standard height= 78.25"
- double sided



RETRACTOR 5

36" WIDE RTRC-5

- standard height= 79.375"
- velcro graphic application



RETRACTOR 6

31.5" WIDE RTRC-6

- standard height= 78.75"
- snap-edge graphic rail



TELESCOPIC 1

23.5" WIDE TEL-1

- variable height= 36"-70"
- single or double sided

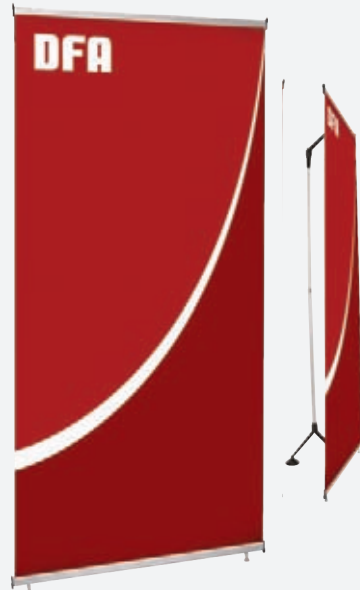

TELESCOPIC 2

39" WIDE TEL-2

- variable height= 60.25"-89"

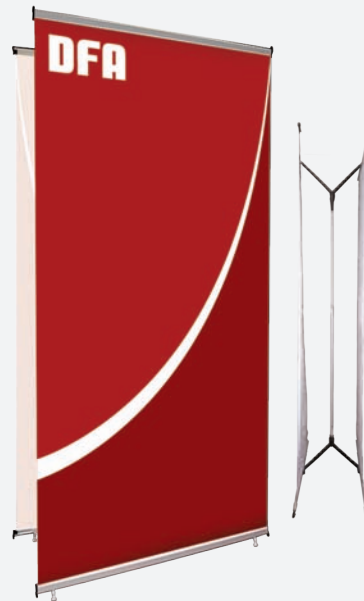

TELESCOPIC 3

39" WIDE TEL-3

- variable height= 60.25"-89"

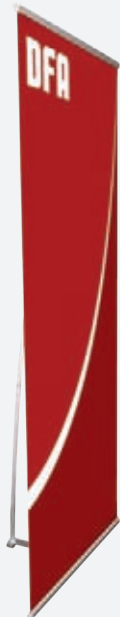

TELESCOPIC 4

31" WIDE TEL-4

- standard height= 77"



DFA products are functional and reliable. They offer the cost effective advantage of lighter and simpler construction, making them a very economic choice.

All DFA banners come with a bag and are an eco-friendly choice.

All DFA banners come with a 90 day warranty.



SPRING 1-1

24" WIDE SB-1-1

- height= 59" or 78.5"



SPRING 1-2

27" WIDE SB-1-2

- height= 59" or 78.5"



SPRING 1-3

35.25" WIDE SB-1-3

- height= 59" or 78.5"



SPRING 3

27.5" WIDE SB-3

- standard height= 70.75"
- #3 grommets in corners



SPRING 4

30" WIDE SB-4

- standard height= 60"
- #3 grommets in corners



SPRING 5

31.5" WIDE SB-5

- standard height= 70.75"
- indoor or outdoor use
- single or double sided



SPRING 6

24.5" WIDE SB-6

- standard height= 63"
- #3 grommets in corners



SPRING 7

29.5" WIDE SB-7

- variable height= 61.5"-69"
- #3 grommets in corners



TT

black & grey: TT-D-4-BK/GRY
 blue & grey: TT-D-BL/GRY



- lightweight, fabric covered tabletop display
- available in 2 front & back color combinations: black/grey, blue/grey (shown with optional graphic panels)

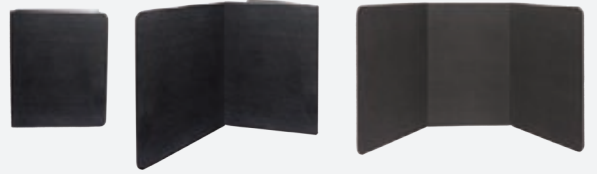

RETRACTOR 7

31" WIDE RTRC-2



- standard height= 78.5"



SCROLLER 1

28.75" WIDE SC-1



- variable height= 48"- 72"
- top scrolling mechanism allows for a variety of lengths and styles
- utilizes standard 110v power



LR 1 & LR 2

4 pocket: LR-1
 8 pocket: LR-2



- modular, roll-up mesh design
- assembles in seconds
- holds standard 8.5"x11" literature
- 4 or 8 pocket model
- black with chrome accent

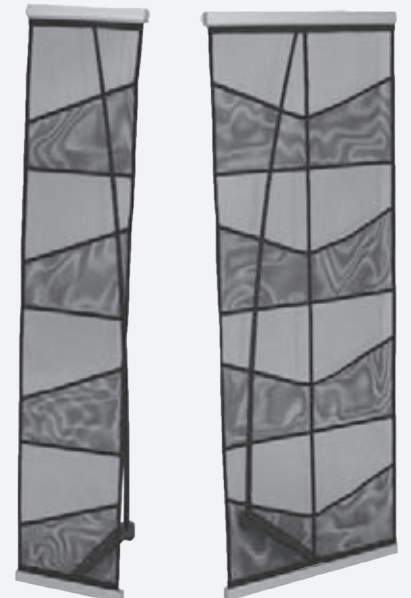



AERO **NEW**  **ONE YEAR**

- indoor modular display system
- adjustable heights & angles
- kit includes three 1200mm wide banners, four light fittings & bags in an OCH2 molded case
- shown with optional Lumina 200 floodlights, sold separately
- available "à la carte" to create more combinations



kit comes complete as shown above



shown with additional panels and lights



OBSERVE GRAND
OBG-B

- sleek info center includes sturdy base & adjustable shelf



OBSERVE PRO
OBS-LP-SYS

- lightweight snap together design
- 12" diameter base
- stylish curved header
- adjustable brochure holder
- accepts 8.5" x 11" graphic and literature
- molded sign clamp will hold an 1/8" thick mounted graphic





HOPUP

- lightweight, heavy duty silver frame
- supports an integrated fabric graphic mural (end caps also available)
- quick & easy setup and pack up
- rolling carry bag included with all units
- 3x3 frame pictured is shown with optional lights (LUM-200-ORL)



STRAIGHT HOPUP CONFIGURATIONS



HOP-2X1-S
approximate front dimensions:
60.25" x 31"



HOP-2X2-S
approximate front dimensions:
60.25" x 60.25"



HOP-3X2-S
approximate front dimensions:
89.25" x 60.25"



HOP-1X3-S
approximate front dimensions:
31" x 89.25"



HOP-2X3-S
approximate front dimensions:
60.25" x 89.25"

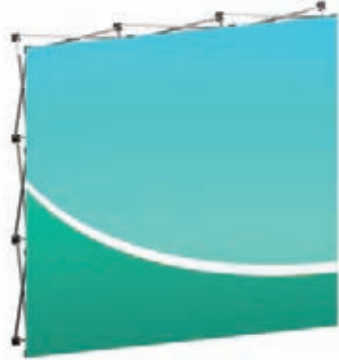

HOP-3X3-S
approximate front dimensions:
89.25" x 89.25"

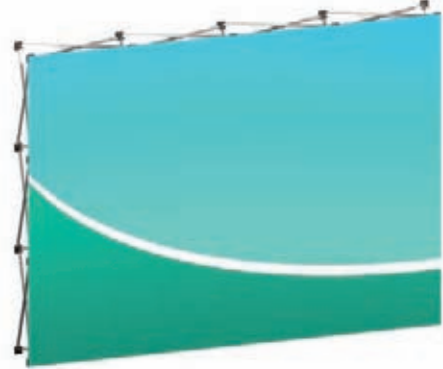

HOP-4X3-S
approximate front dimensions:
118.25" x 89.25"

CURVED HOPUP CONFIGURATIONS



HOP-3X3-C
approximate front dimensions:
60.25" x 89.25"

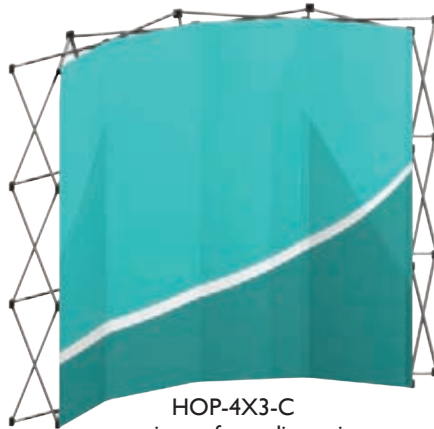

HOP-4X3-C
approximate front dimensions:
60.25" x 89.25"

- lightweight, heavy duty silver frame
- curved frame provides a unique look
- quick & easy setup and pack up
- rolling carry bag included with all units
- 3x3 curved frame pictured is shown with optional end caps

HOPUP COUNTER

HOP-CT-S



- collapsible display counter
- very portable & lightweight
- includes black internal shelf
- hinged top available in all four laminate finishes
- the perfect complement to your Hopup fabric backwall





- fully magnetic popup display system providing a graphic or fabric backwall
- available in a wide range of size configurations (see page 15)





OCP



OCP

- general purpose transit case
- blow molding makes case strong yet lightweight
- built in wheels, handle
- light storage in the lid
- secure reinforced straps help to assure case will remain closed during transport
- recommended for Coyotes & Hopups



CASE TO COUNTER CONVERSION

Roll Wrap: OCP-C2C-G



- available in fabric or graphic
- converts OCP to a counter
- polymer counter surface exposed



Stretch Wrap: OCP-SW-G



- stretch fabric pullover
- converts OCP to a counter
- polymer counter surface covered by fabric



OCP ELITE

OCP-ELITE



- heavy duty shipping and storage case
- lid can be used as a step stool while assembling displays
- access door provides storage when unit is used as a counter
- UPS approved



CASE TO COUNTER CONVERSION

Roll Wrap: ELITE-C2C-G



- available in fabric or graphic
- converts OCP Elite to a counter
- counter surface exposed



Stretch Wrap: ELITE-SW-G



- stretch fabric pullover
- converts OCP Elite to a counter
- counter surface covered by fabric

OCS AND OCL

small: OCS
large: OCL



- blow molded cases for exhibits & graphics
- reliable built-in wheels
- easy-to-grip molded handles
- secure reinforced straps help to assure case will remain closed during transport



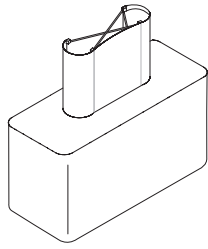

1x1 tabletop
footprint dimensions:
30.625"h x 45.5"w x 12.5"d

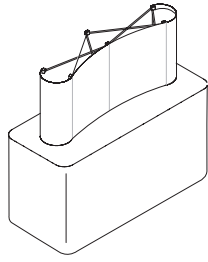

2x1 tabletop
footprint dimensions:
30.625"h x 73"w x 19.25"d

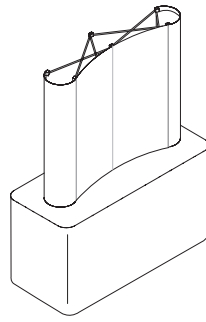

2x2 tabletop kit
footprint dimensions:
59.375"h x 73"w x 19.25"d

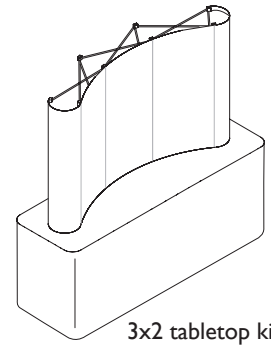

3x2 tabletop kit
footprint dimensions:
59.375"h x 97.25"w x 25"d

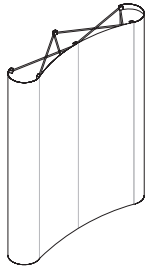

2x3 full height
slim-line display system
footprint dimensions:
87.56"h x 73"w x 19.25"d

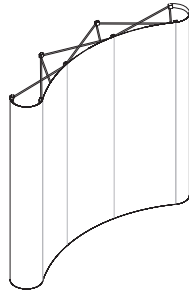

3x3 full height
standard display system
footprint dimensions:
87.56"h x 97.25"w x 25"d

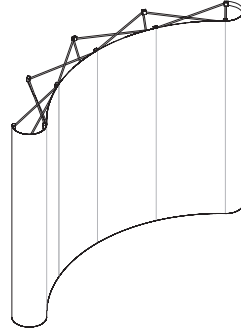

4x3 full height
standard display system
footprint dimensions:
87.56"h x 118"w x 36.5"d

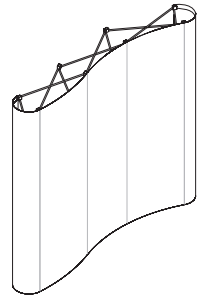

3x3 serpentine
full height display system
footprint dimensions:
87.56"h x 89.5"w x 19.5"d



4x3 serpentine
full height display system
footprint dimensions:
87.56"h x 129.5"w x 19.5"d

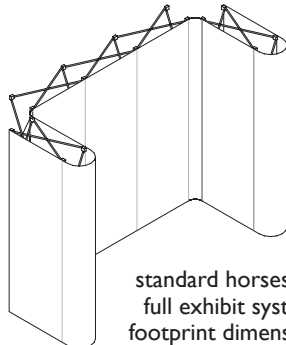

standard horseshoe
full exhibit system
footprint dimensions:
87.56"h x 113"w x 54"d

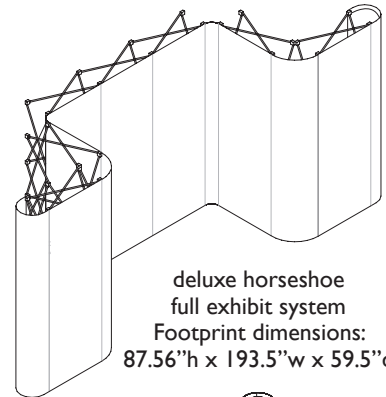

deluxe horseshoe
full exhibit system
Footprint dimensions:
87.56"h x 193.5"w x 59.5"d

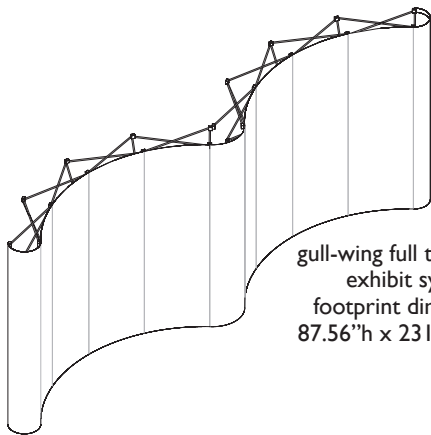

gull-wing full trade show
exhibit system
footprint dimensions:
87.56"h x 231"w x 41"d

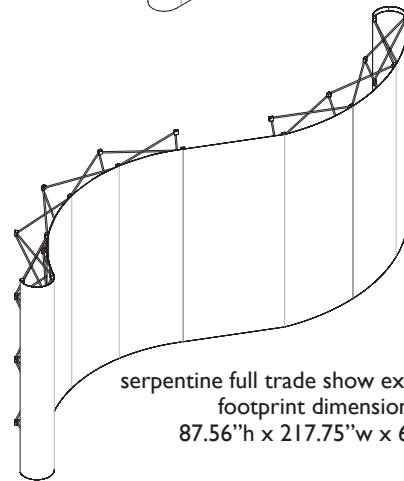

serpentine full trade show exhibit system
footprint dimensions:
87.56"h x 217.75"w x 60.5"d

FABRIC CHOICES

All Coyote popup display systems are available with printed graphic murals or "velcro-friendly" fabric panels of your choice. Actual fabric color may vary slightly.

Regal - smooth exhibit & display fabric



Premier - ribbed exhibit & display fabric

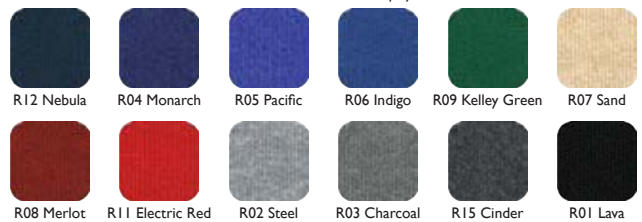

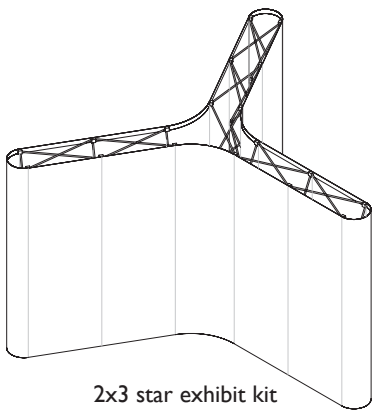

2x3 star exhibit kit

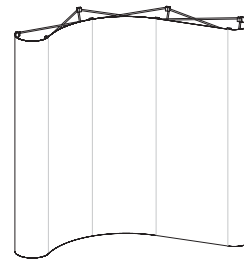
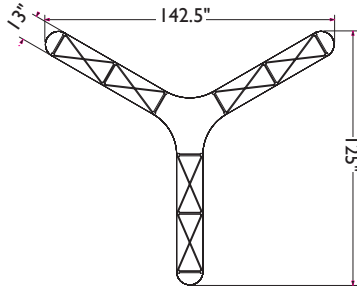

3x3 "L" exhibit kit

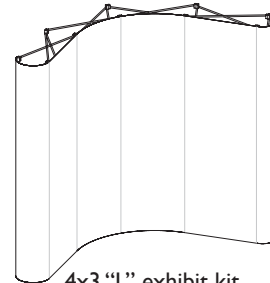
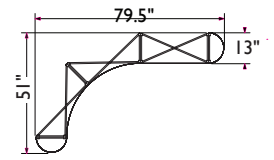

4x3 "L" exhibit kit

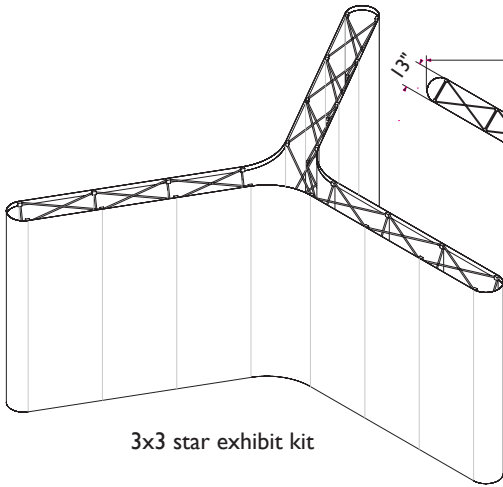
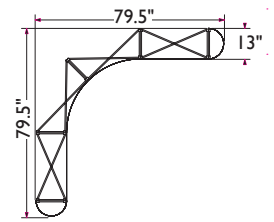

3x3 star exhibit kit

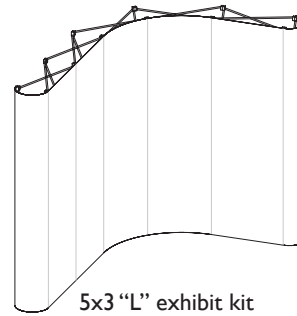
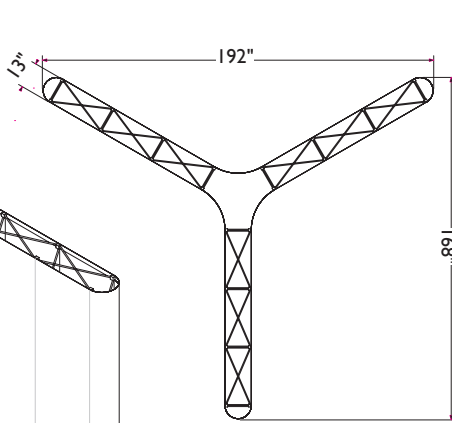

5x3 "L" exhibit kit

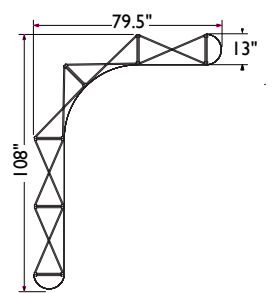

COYOTE ACCENT KIT
COY-ACCT-K



- a fresh new look for your Coyote popup
- update your current display with 2 modern wing shapes and 4 extrusions



COYOTE TOWER
COY-3-G-TOW



- an unexpected addition to any display; large or small, exhibit or P.O.P
- back-lit panels illuminate your graphics
- coordinates with the look and style of your Coyote popup display



the **COYOTE**
MINI popup



- approx. 20% smaller than standard Coyote tabletops
- entire display rolls up into special storage sleeve which slides into a padded carry case
- kit includes frame, channel bars, panel hangers, carry case, & 2 lights
- add an optional OCS hard case for shipping or extra secure storage



2x2 mini tabletop kit
footprint dimensions:
48" h x 53.625" w x 11.75" d



3x2 mini tabletop kit
footprint dimensions:
48" h x 74.625" w x 15.75" d

COYOTE OPTIONS

Customize your Coyote display with a variety of optional accessories.



Lumina 200 & Lumina 7 are excellent lighting solutions for your Coyote popup exhibit (see page 48)



INTERNAL SHELF KIT



- presents products or literature
- comes with 2 clear acrylic shelves to be used horizontally or at 45° angles
- max capacity per shelf= 15 lbs, max per quadrant= 45 lbs
- for use with curved frame only
- **lighting package available**



MONITOR MOUNT



- combine print and digital images to strengthen your message
- fully integrated with straight or curved Coyote systems
- one panel will be cut to fit the monitor and feet
- LCD max size= 32"
- (not recommended for plasma or CRT units)

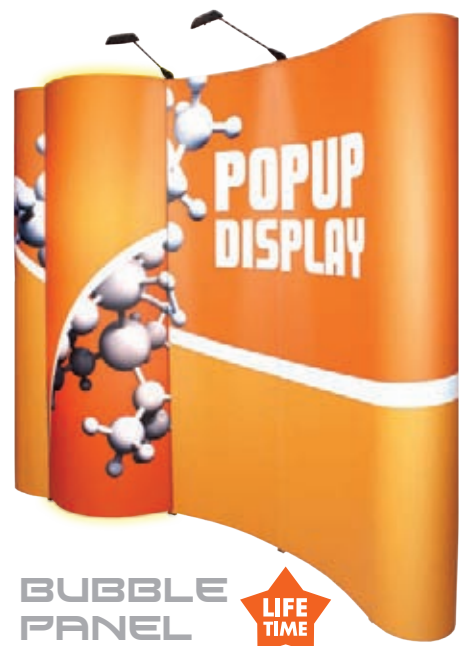

BUBBLE PANEL



- forward facing, convex panel
- panel can be fabric, opaque graphic or rear illuminated graphic (light kit sold separately)
- hardware can be stored with display in OCP



side mounted
tables available
on vertically
curved
Formulate
backwalls



NEW



FORMULATE

- advanced aluminum structure
- rugged plastic molded transit & storage case
- step-by-step instructions
- some kits include: front curved accents, low voltage lighting, tabletops and/or counter, literature pockets, headers and top accents

FORMULATE TABLETOP

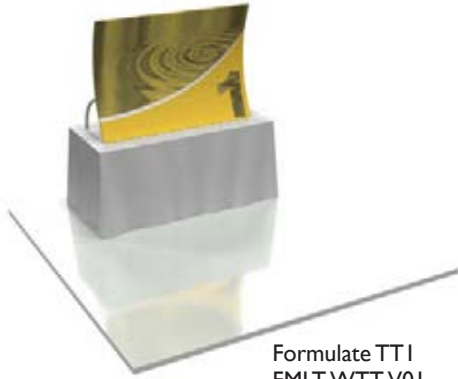

Formulate TT1
FMLT-WTT-V01

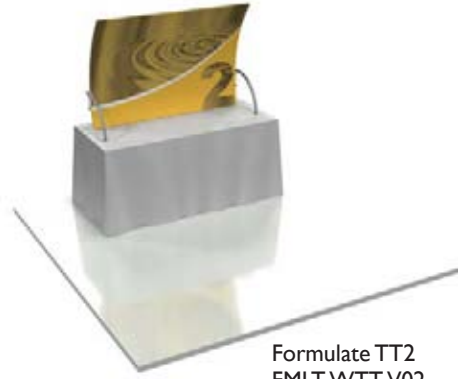

Formulate TT2
FMLT-WTT-V02

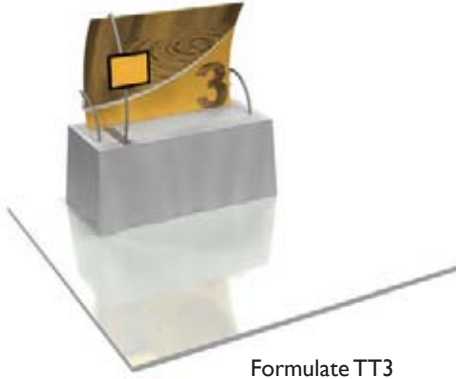

Formulate TT3
FMLT-WTT-V03

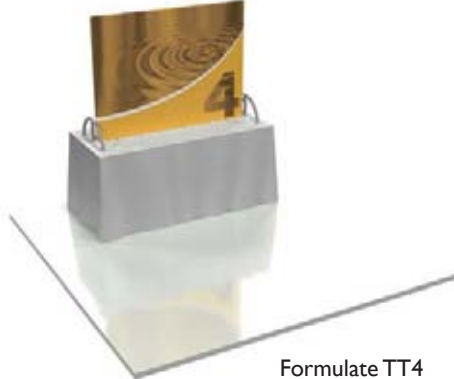

Formulate TT4
FMLT-WTT-V04

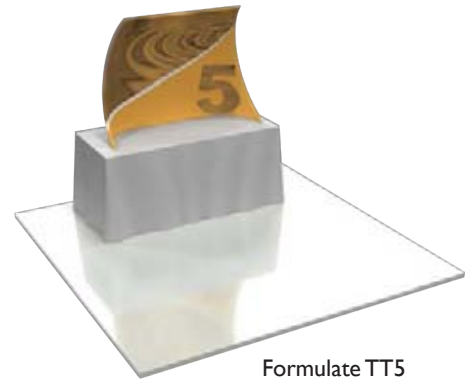

Formulate TT5
FMLT-WTT-V05

FORMULATE STRAIGHT BACKWALLS



Formulate S1
FMLT-WS8-01



Formulate S2
FMLT-WS8-02



Formulate S3
FMLT-WS8-03



Formulate S4
FMLT-WS8-04

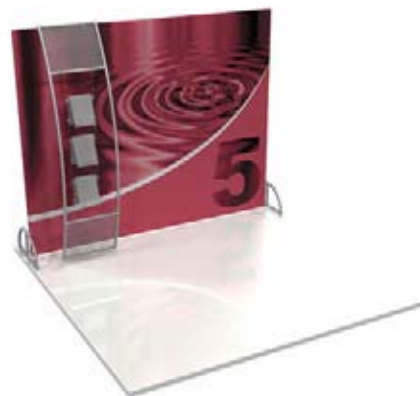

Formulate S5
FMLT-WS8-05



All Formulate structures come with a lifetime warranty.

FORMULATE HORIZONTALLY CURVED BACKWALLS



Formulate HC1
FMLT-WH10-01



Formulate HC2
FMLT-WH10-02

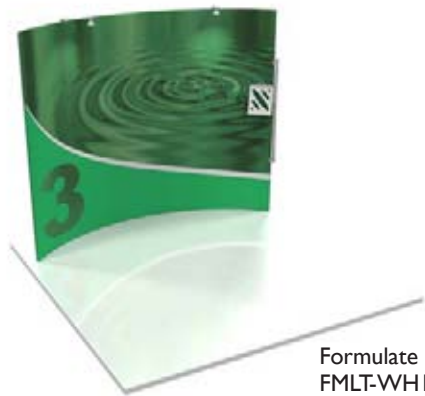

Formulate HC3
FMLT-WH10-03

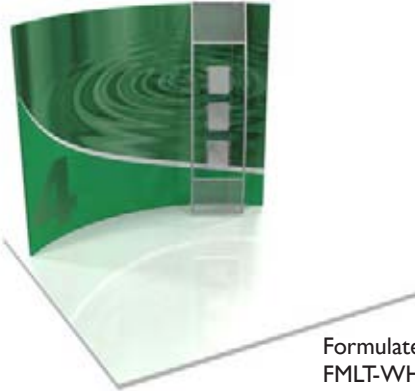

Formulate HC4
FMLT-WH10-04

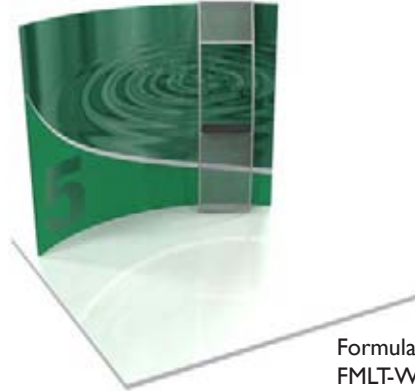

Formulate HC5
FMLT-WH10-05

FORMULATE VERTICALLY CURVED BACKWALLS



Formulate VC1
FMLT-WV10-01

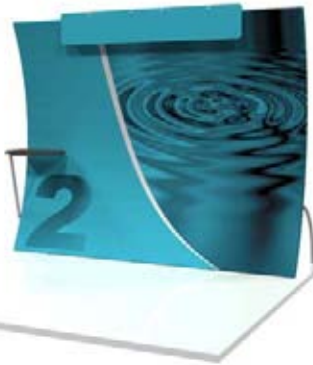

Formulate VC2
FMLT-WV10-02



Formulate VC3
FMLT-WV10-03

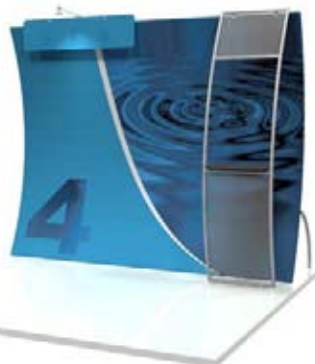

Formulate VC4
FMLT-WV10-04

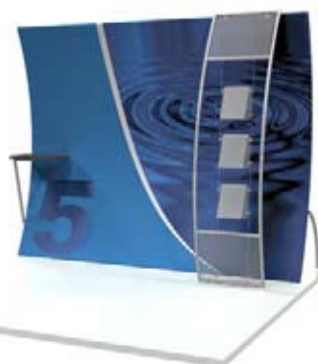

Formulate VC5
FMLT-WV10-05



All Formulate structures come with a lifetime warranty.

FORMULATE 8' BACKWALLS



Formulate 8S
FMLT-WS8-01



Formulate 8H
FMLT-WH8-01



Formulate 8V
FMLT-WV8-01

FORMULATE 20' BACKWALLS

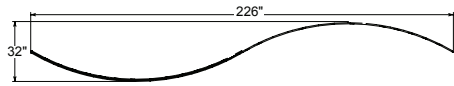

Formulate 20S
FMLT-WS20-01

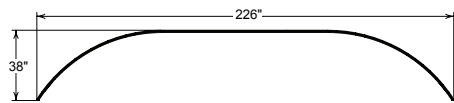

Formulate 20H
FMLT-WH20-01

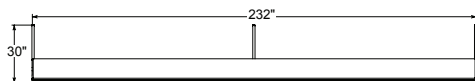

Formulate 20V
FMLT-WC20-01



All Formulate structures come with a lifetime warranty.

FORMULATE HANGING STRUCTURES

RING

- 8' diam. x 3'h
- 10'9" diam. x 4'h
- 12' diam. x 4'h
- 14' diam. x 4'h
- 16' diam. x 4'h
- 18' diam. x 4'h
- 20' diam. x 4'h

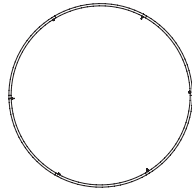

TAPERED RING

- 8' diam. x 3'h
- 10'9" diam. x 4'h
- 12' diam. x 4'h
- 14' diam. x 4'h
- 16' diam. x 4'h
- 18' diam. x 4'h
- 20' diam. x 4'h

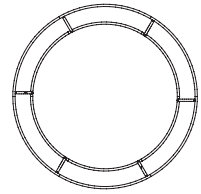

FOUR SIDED

- 8'w x 3'h
- 8'10"w x 4'h
- 12'w x 4'h
- 14'w x 4'h
- 16'w x 4'h
- 18'w x 4'h
- 20'w x 4'h

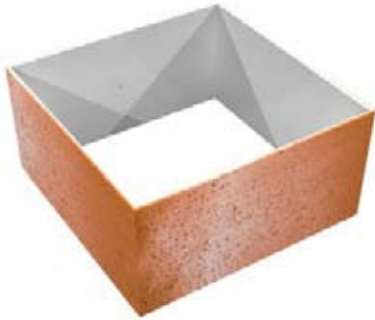
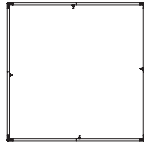

FOUR SIDED

- 10'w x 4'h
- 12'w x 4'h
- 16'w x 5'h
- 20'w x 5'h

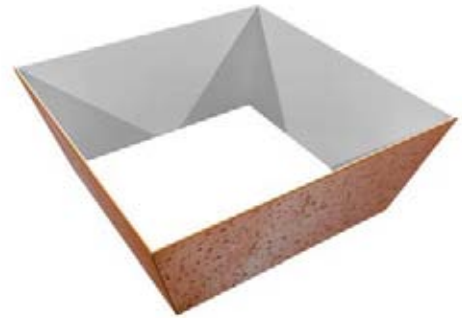
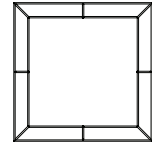

CONCAVE FOUR SIDED

- 8'10"w x 3'h
- 8'10"w x 4'h
- 12'w x 4'h
- 14'w x 4'h
- 16'w x 4'h
- 18'w x 4'h
- 20'w x 4'h

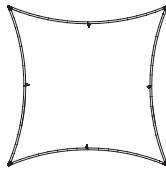

THREE SIDED

- 6'w x 3'h
- 10'9"w x 4'h
- 12'w x 4'h
- 14'w x 4'h
- 16'w x 4'h
- 18'w x 4'h
- 20'w x 4'h

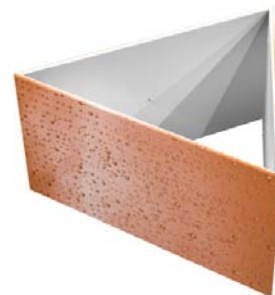
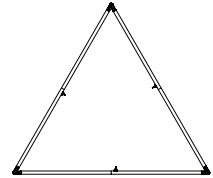

All Formulate structures come with a lifetime warranty.

TAPERED THREE SIDED

10'w x 4'h
 12'w x 4'h
 16'w x 5'h
 20'w x 5'

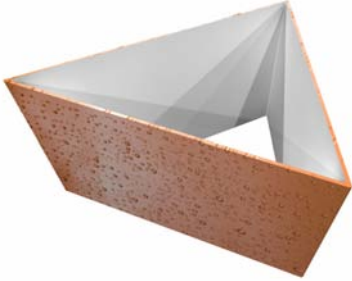
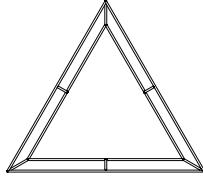

CONVEX THREE SIDED

8'9''w x 3'h
 8'9''w x 4'h
 12'w x 4'h
 20'w x 5'h

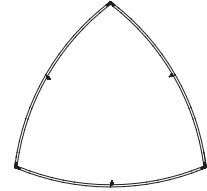

PINWHEEL

8'9''w x 3'h
 8'9''w x 4'h
 12'w x 4'h
 16'w x 4'h
 20'w x 4'h



RECTANGLE

12'l x 6'w x 4'h
 16'l x 8'w x 5'h
 20'l x 10'w x 5'h

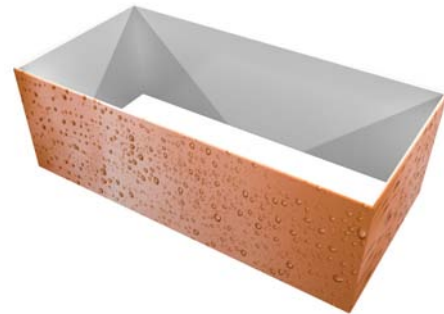
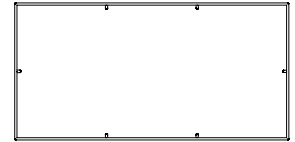

FOOTBALL

12'l x 4'h
 15'l x 4'h
 20'l x 5'h

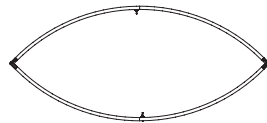

FOUR SIDED PYRAMID

10'w x 5'h
 12'w x 6'h
 16'w x 8'h
 20'w x 10'h

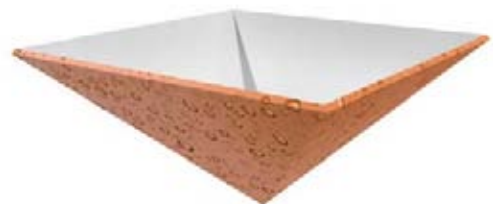
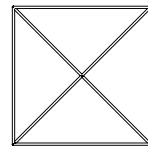

THREE SIDED PYRAMID

10'w x 5'h
12'w x 6'h
16'w x 8'h
20'w x 10'h

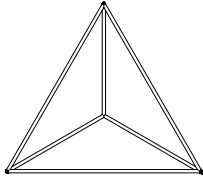

ROUND FUNNEL

10'w x 4'h

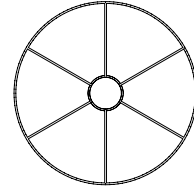

SQUARE FUNNEL

10'w x 4'h

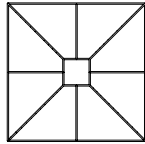

CONE

10'w x 5'h
12'w x 6'h
16'w x 8'h
20'w x 10'h

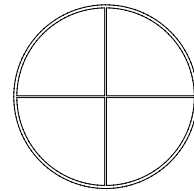

CURVE

8'w x 3'h
8'9''w x 4'h
12'w x 4'h
15'w x 4'h
16'w x 4'h
20'w x 4'h
20'w x 6'h



DISC



8' diameter
10'9'' diameter
12' diameter
14' diameter
16' diameter
18' diameter
20' diameter

PANEL

8'w x 3'h
8'9''w x 4'h
12'w x 4'h
15'w x 4'h
16'w x 4'h
20'w x 4'h
20'w x 6'h



S-CURVE



8'w x 3'h
17'w x 4'h
12'w x 4'h
12'w x 6'h
16'w x 4'h
16'w x 6'h
20'w x 6'h



All Formulate structures come with a lifetime warranty.

TABLE THROW

- 4 foot full: TBL-T-4-F
- 4 foot economy: TBL-T-4-E
- 6 foot full: TBL-T-6-F
- 6 foot economy: TBL-T-6-E
- 8 foot full: TBL-T-8-F
- 8 foot economy: TBL-T-8-E



- complete your presentation with a dye-sub printed table throw
- lends a polished appearance to any display
- maximize your advertising with additional space to display your message



shown with Horizon Standard tabletop folding panel display (see page 22)



4' table throws now available for smaller tables



TABLE RUNNERS

- 24" full: TBL-R-24-F
- 24" economy: TBL-R-24-E
- 30" full: TBL-R-30-F
- 30" economy: TBL-R-30-E
- 60" full: TBL-R-60-F
- 60" economy: TBL-R-60-E



- accent your solid colored table throw with a full color printed runner
- available in 3 widths



CONVERTIBLE TABLE THROW



- convertible full: TBL-T-FC
- convertible economy: TBL-T-EC

- converts quickly and easily to fit both a 6' and 8' table
- Velcro tabs make conversion simple



IMPRINTED TABLE THROW



- 6 foot full
- 6 foot economy
- 8 foot full
- 8 foot economy

- 11 standard tablethrow colors
- maximum logo size= 60" w x 21.5" h (see template for details)
- must be simple vector artwork, no complex logos or gradients
- referenced Pantone colors are not exact



carry bag available
TBL-THRW-BG



full table throw shown in white fabric with blue and sapphire imprinted vinyl



economy table throw leaves back of table exposed for easy access to storage



economy table throw shown in royal blue fabric with white imprinted vinyl

FULL TABLE THROW

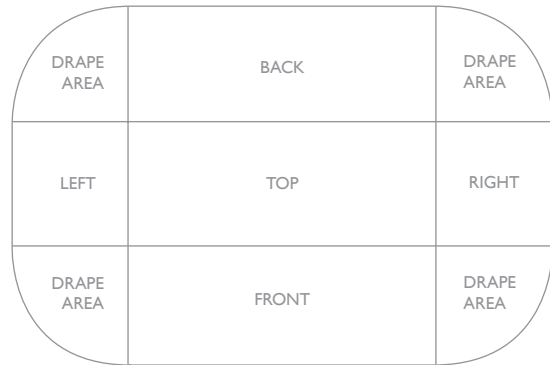

ECONOMY TABLE THROW

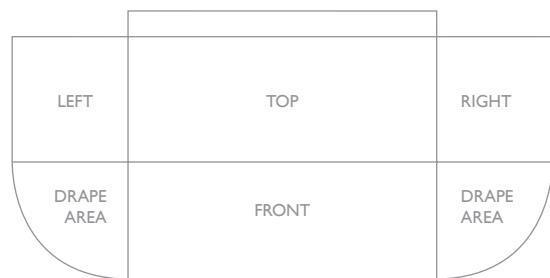

FABRIC COLORS



VINYL COLORS



HORIZON 6

WEIGHS 22 LBS HZ-6



- main panel sizes approximately= 2' x 3'
- custom sized panel displays are available
- shown with optional detachable graphics
- available in a variety of fabric color options (page 23)



TABLETOP | STANDARD

WEIGHS 12 LBS HZ-TT-S



- 3 panels plus a header
- shown with optional detachable graphics
- available in a variety of fabric color options (page 23)

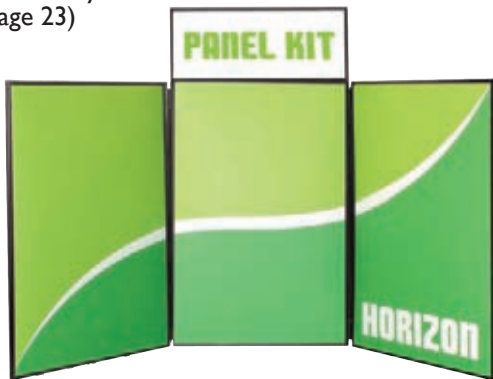

TABLETOP | DELUXE MASTER

WEIGHS 13.5 LBS HZ-TT-M



- detachable graphics available
- available in a variety of fabric color options (page 23)



HORIZON 8

WEIGHS 31 LBS HZ-8

- 8 panel kit
- complete backwall with 2 headers
- detachable graphics available
- available in a variety of fabric color options (page 23)



EFEX

- 2801 three panel kit: EFX-2801
- 2802 three panel kit w/header: EFX-2802

- lightweight, fabric covered tabletop display, 28" w x 35" h



- available in a choice of 4 basic color combinations:

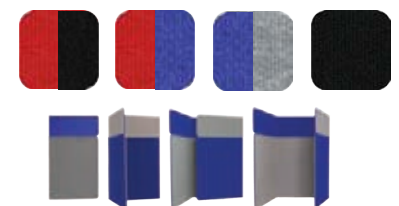

HERO

- durable premium seamless exhibit panel kits
- convenience of folding panels with elegant, seamless panel construction
- concealed hinges
- unique 2" radius curved ends lend a polished appearance
- full height units can also be used as two tabletop units
- available in a variety of fabric color options
- shown with optional detachable graphics

OCH CASE



shown with optional graphics
HERO H16

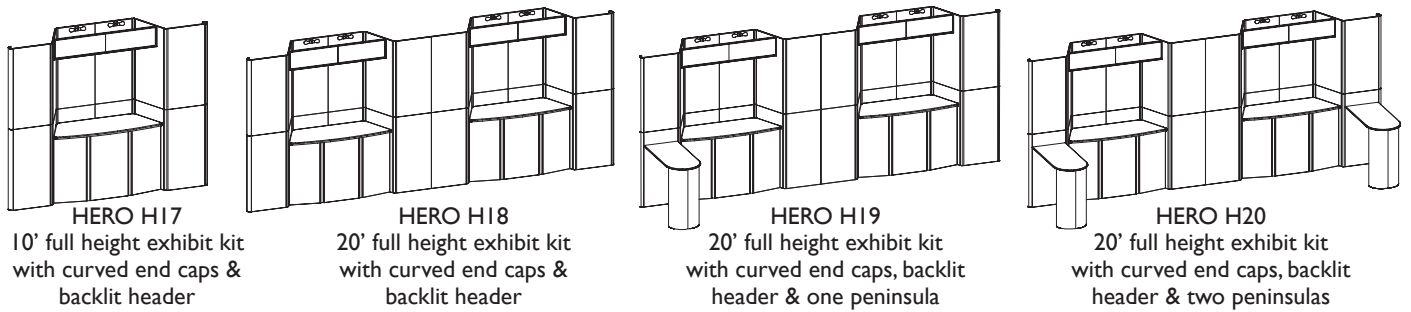
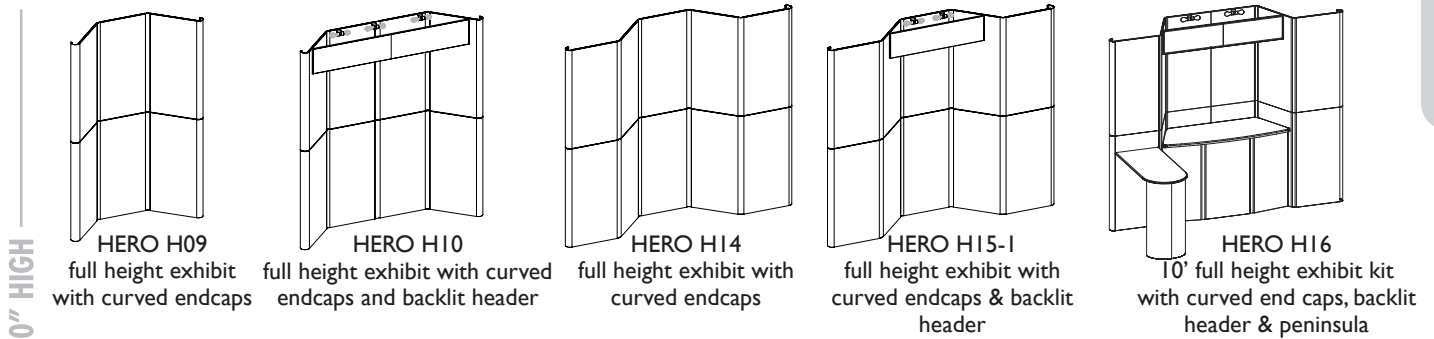
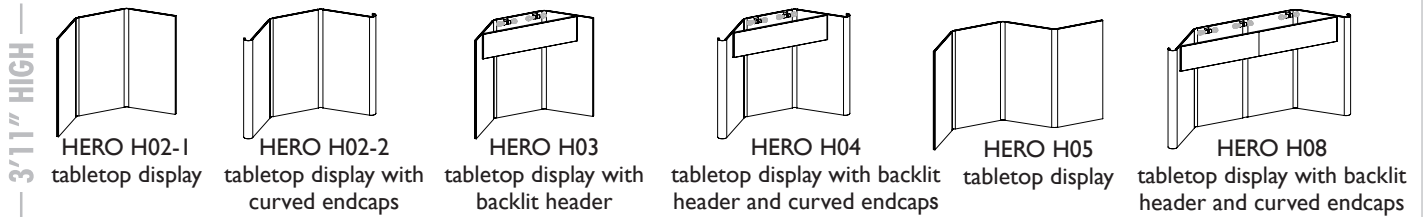

FABRIC CHOICES

All Hero & Horizon folding display panels are available with detachable graphic panels or "velcro-friendly" fabric panels of your choice. Actual fabric color may vary slightly.

Regal - smooth exhibit & display fabric



Premier - ribbed exhibit & display fabric

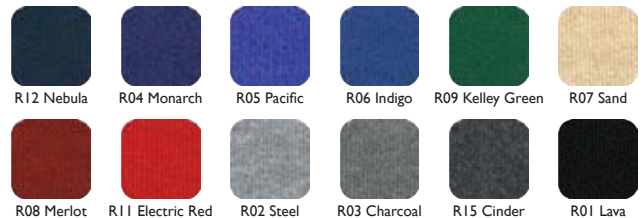

VOYAGER

24 SERIES

The Voyager has been specially developed as a briefcase style table top display and is a great choice for promotions on the go. It has a rigid, thermo formed ABS exterior and a black, Velcro compatible fabric interior.

All units are shown with Velcro detachable graphics. Header options shown with V-2 and V-3 models are also available for V-1.



FOLDING DISPLAY PANELS

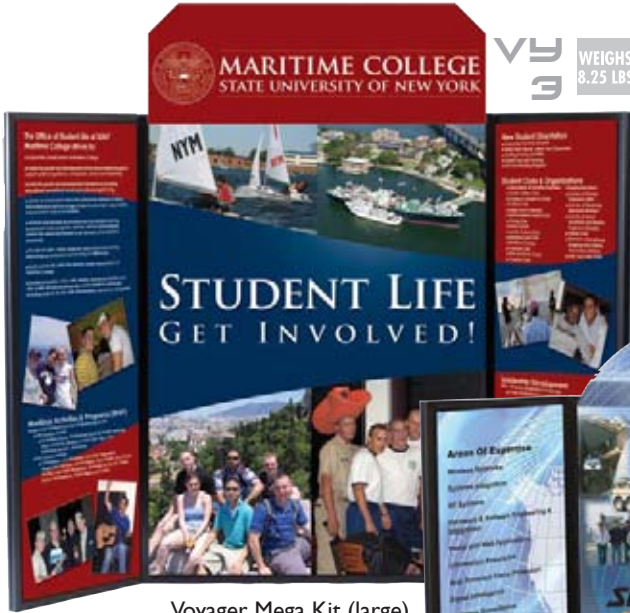

Voyager Mega Kit (large)
open dimensions: 32" h x 48" w
closed dimensions: 32" h x 24" w

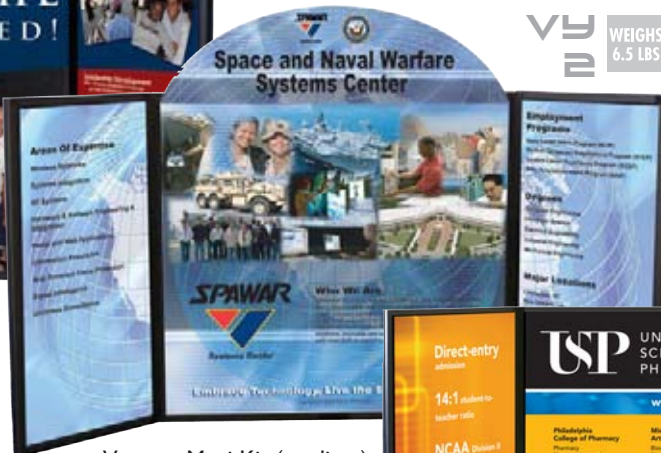

Voyager Maxi Kit (medium)
open dimensions: 24" h x 48" w
closed dimensions: 24" h x 24" w



Voyager Mini Kit (small)
open dimensions: 18" h x 48" w
closed dimensions: 18" h x 24" h



VOYAGER CARRY BAG

- Voyager Mini bag: VY-1-BG
- Voyager Maxi bag: VY-2-BG
- Voyager Mega bag: VY-3-BG
- Voyager Supreme bag: VY-4-BG
- Voyager Monster bag: VY-5-BG



CUSTOMIZE

Brand the exterior of your Voyager to match your company and/or product colors to maximize your marketing efforts. Minimum 12 units, call for details.

32 SERIES

All Voyager systems have a limited Lifetime Warranty. Internal graphics can remain on the Voyager during transport. Header options should be removed for transport and storage.



VY 5
WEIGHS 10 LBS



Voyager Monster kit (xx-large)
open dimensions: 32”h x 64”w
closed dimensions: 32”h x 32”w

Detachable graphics allow for easy changes! Extra graphics can be stored in the display case and packed away for easy storage.



Voyager Supreme kit (x-large)
open dimensions: 24”h x 64”w
closed dimensions: 24”h x 32”w

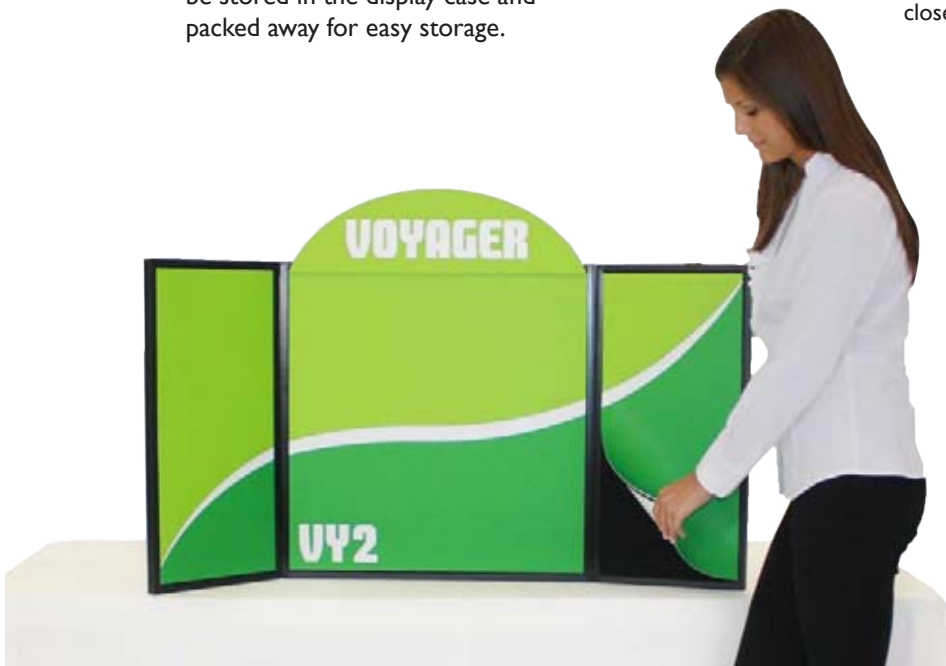

Carry your Voyager hands-free by adding a water-resistant canvas carry bag with shoulder strap. Stores header, extra graphics & literature.

V-CLASS COUNTER

- your choice of four standard patterns, custom graphic option also available
- countoured design creates a refined, substantial look
- quick & simple assembly
- wire management option available
- comes with an OCH shipping & transport case



PERSONALIZE YOUR V-CLASS

front, back & top are available in your choice of finishes



Silver Black Mahogany Natural

sides are available in your choice of printed patterns



Steel Black Perf Metal Diamond Plate Granite

counter tops are available in your choice of shapes

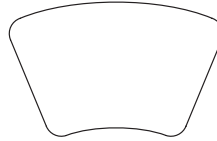

Quad

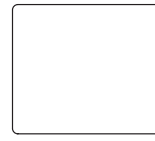

Square

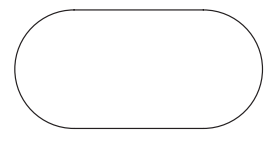

Racetrack



repositionable shelves adjust to your storage needs

CAMPAIGN

CP-BI

- quick assembly
- strong & easy to clean plastic parts



HOPUP COUNTER

HOP-CT-S



- collapsible display counter
- very portable & lightweight
- includes black internal shelf
- hinged top available in all four laminate finishes



counter folds up compact



hinged top makes unit more portable



internal shelving for hideaway storage

SYMPHONY COUNTER



- unique, sleek design lends an attractive element to your tradeshow or POP display
- quick set-up, easy assembly
- modern colors draw attention to your booth
- a perfect complement to your Linear display



Oval Grand
SYM-OV-GRND

counter stretch skirts are available in the following colors



Amethyst Ruby Sapphire Emerald Silver Jet

tops are available in your choice of finishes



Silver Black Mahogany Natural



Oval
SYM-OV



Quad
SYM-QD



Rectangle
SYM-RCT

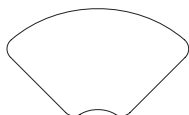

Quad Grand
SYM-QD-GRND

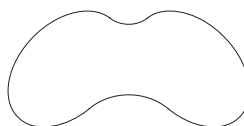

Oval Double Grand
SYM-OV-DBL-GRND

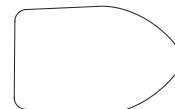

Bullet
SYM-BLLT

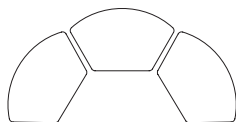

3 Quad Kit
SYM-QD-3

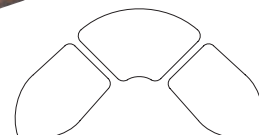

Corner Kit
SYM-CRNR

LINEAR COUNTER

- coordinates with the Linear hybrid modular display line
- 3 graphic panels available to display your custom graphics
- quick & easy to assemble, tool included
- fits in our OCH shipping and transport case
- aluminum design is sturdy and stable



tops are available in your choice of finishes

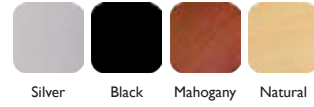

open back allows for hidden storage



user-friendly leg connections



simple & secure cam lock connections

LINEAR MONITOR KIOSK KITS

- hybrid modular display systems
- each kit comes standard with a 2-section upright post, decorative cap, LCD mounting bracket, PC shelf, & all necessary mounting hardware



tops are available in your choice of finishes

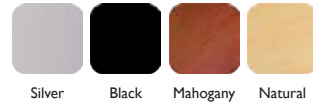

Kit 1
LN-MK-1



Kit 2
LN-MK-2



Kit 3
LN-MK-3



Kit 4
LN-MK-4



Kit 5
LN-MK-5

VECTOR FRAMES

- easy to set up and break down
- clean, simple, sophisticated look
- vibrant tension fabric graphic
- extrusion based
- single or double sided
- heavy duty silver frame and feet



silicone tubing makes for simple graphic installation

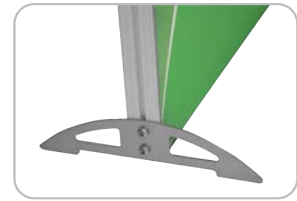

AVAILABLE SIZES:



01 Rectangle
VF-R-01



02 Rectangle
VF-R-02



03 Rectangle
VF-R-03



04 Rectangle
VF-R-04



01 Square
VF-S-01



02 Square
VF-S-02



03 Square
VF-S-03



04 Square
VF-S-04

LINEAR

Linear provides a modern & dynamic enhancement to your marketing message. The range is simple & lightweight, yet provides the strength & versatility to meet the needs of today's demanding exhibit or event requirements.



LINEAR TABLETOP KITS

- simple & lightweight
- cost effective
- takes minutes to assemble
- advanced aluminum structure
- stylish 50 watt low voltage
- rugged plastic molded transit & storage case
- step-by-step setup instructions
- fully customizable, high quality digitally printed graphic options available

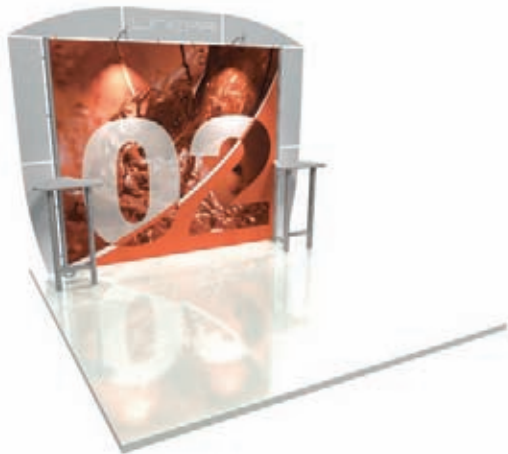

LINEAR STANDARD KITS

- simply stylish
- slim structure emphasizes the primary focus
- quick set up
- advanced aluminum structure
- stylish 50 watt low voltage
- rugged plastic molded transit & storage case
- step-by-step setup instructions
- options include: LCD mounts, tabletops & counters, literature pockets, larger freight cases
- fully customizable, high quality digitally printed graphic options available



LINEAR PRO KITS

- hybrid modular display systems
- quick set up
- stylish wing design options
- extrusion structure is complemented by a fabric canopy
- advanced aluminum structure
- stylish 50 watt low voltage
- rugged plastic molded transit & storage case
- step-by-step setup instructions
- options include: LCD mounts, tabletops & counters, literature pockets, larger freight cases
- fully customizable, high quality digitally printed graphic options available



LINEAR BOLD KITS

- hybrid modular display systems
- quick set up
- stylish wing design options
- broad structure creates a dynamic & imposing framework
- advanced aluminum structure
- stylish 50 watt low voltage
- rugged plastic molded transit & storage case
- step-by-step setup instructions
- options include: LCD mounts, tabletops & counters, literature pockets, larger freight cases
- fully customizable, high quality digitally printed graphic options available

LINEAR TABLETOP KITS

- hybrid modular display systems
- quick set up
- stylish wing design options



LINEAR

LINEAR TABLETOPS



LINEAR | TABLETOP KITS



Kit AA
LN-K-TT-AA



Kit BB
LN-K-TT-BB



Kit CC
LN-K-TT-CC



Kit DD
LN-K-TT-DD



Kit EE
LN-K-TT-EE



Kit FF
LN-K-TT-FF



Kit GG
LN-K-TT-GG



Kit HH
LN-K-TT-HH

LINEAR

LINEAR STANDARD

LINEAR | 10' X 10'



Kit 01
LN-K-3P-01

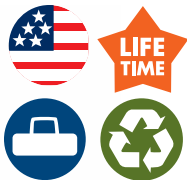

comes in durable molded cases



your choice of table finishes

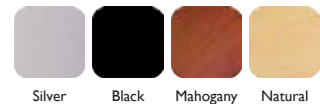

your choice of Lumina lights (2 lights per 10', 4 lights per 20')



Lumina 1 Lumina 3 Lumina 5 Lumina 6 Lumina 8

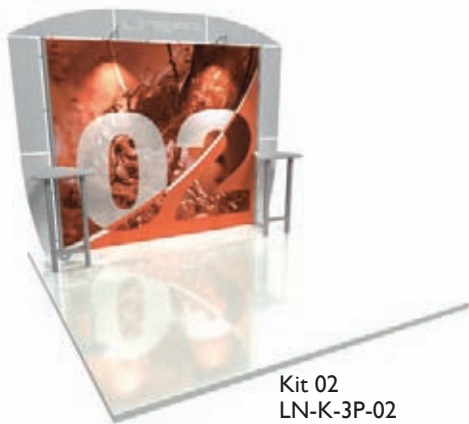

Kit 02
LN-K-3P-02

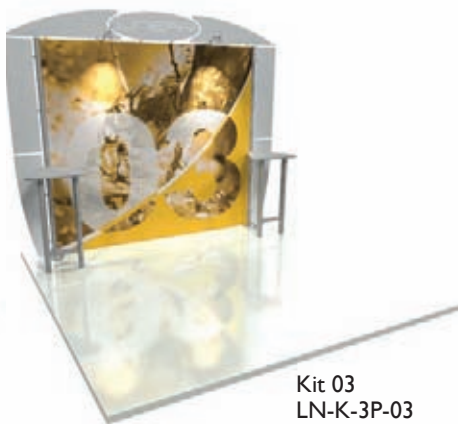

Kit 03
LN-K-3P-03

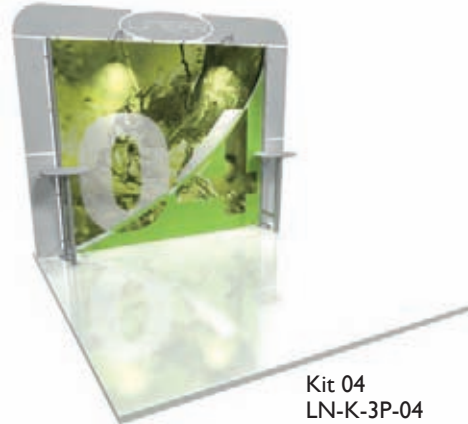

Kit 04
LN-K-3P-04

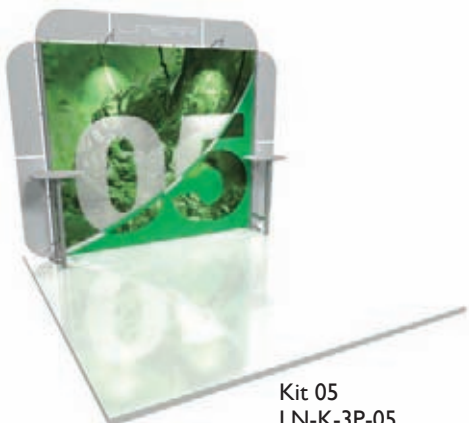

Kit 05
LN-K-3P-05

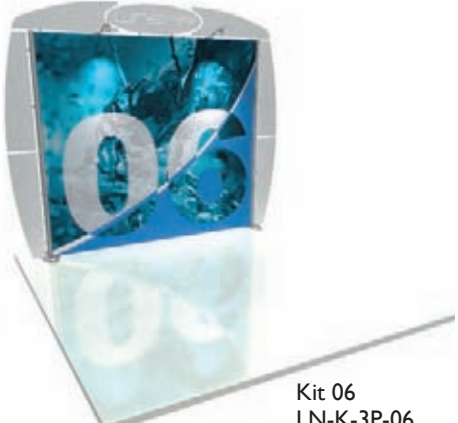

Kit 06
LN-K-3P-06



Kit 07
LN-K-3P-07

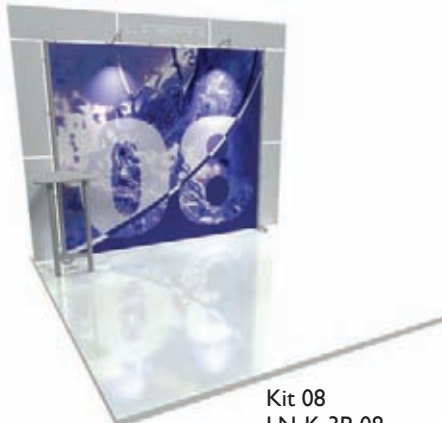

Kit 08
LN-K-3P-08

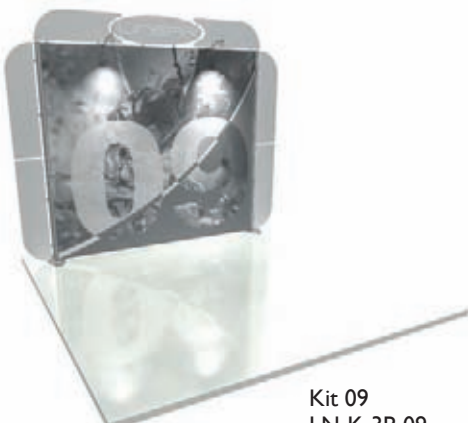

Kit 09
LN-K-3P-09

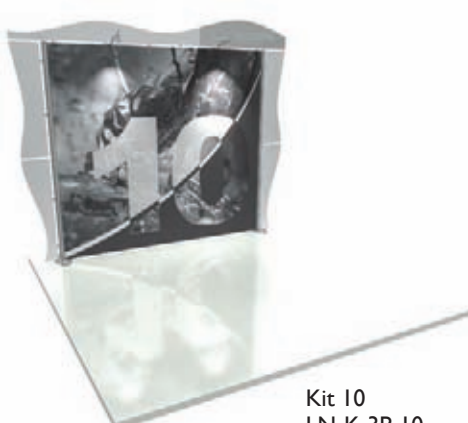

Kit 10
LN-K-3P-10



All Linear kits come with a lifetime warranty.

LINEAR

LINEAR STANDARD



Kit 11
LN-K-3P-11



Kit 12
LN-K-3P-12

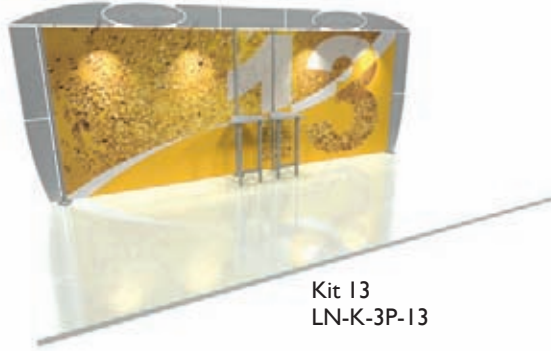

Kit 13
LN-K-3P-13

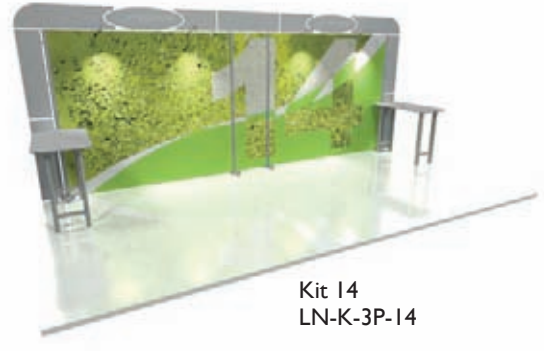

Kit 14
LN-K-3P-14

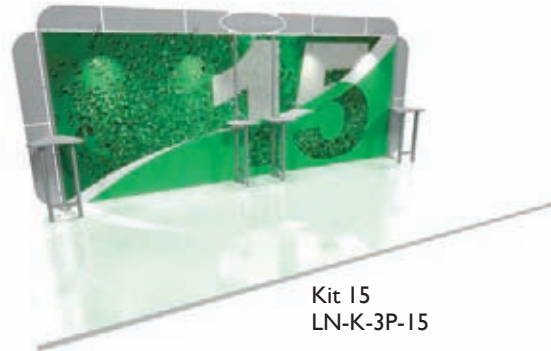

Kit 15
LN-K-3P-15

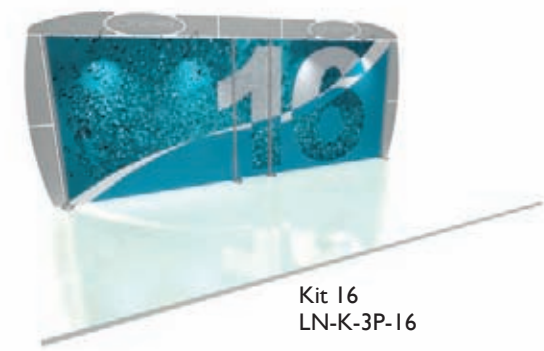

Kit 16
LN-K-3P-16



Kit 17
LN-K-3P-17

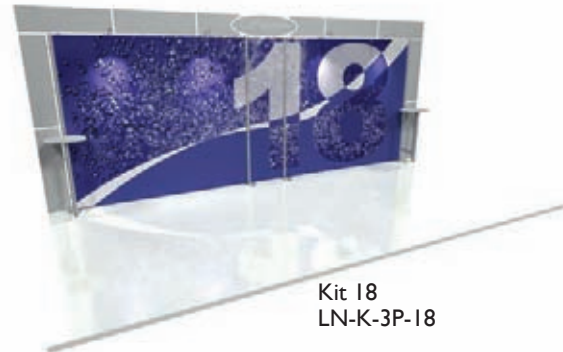

Kit 18
LN-K-3P-18

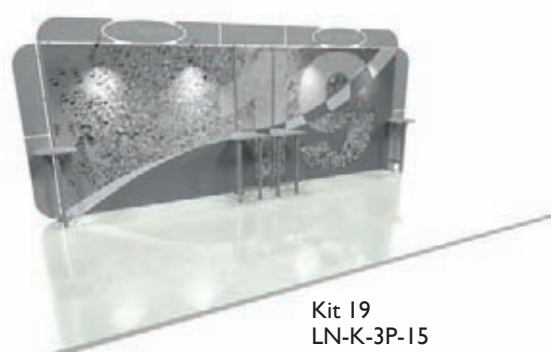

Kit 19
LN-K-3P-19

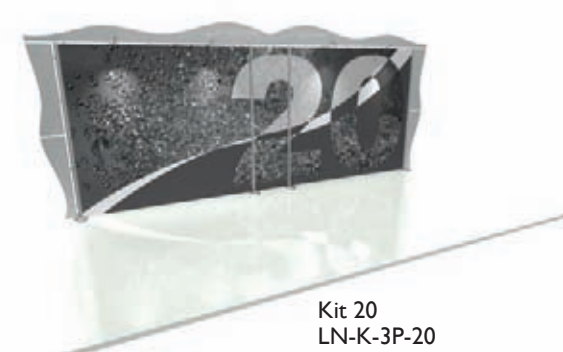

Kit 20
LN-K-3P-20

LINEAR | 10' X 20'

LINEAR

LINEAR PRO 10' X 10' KITS

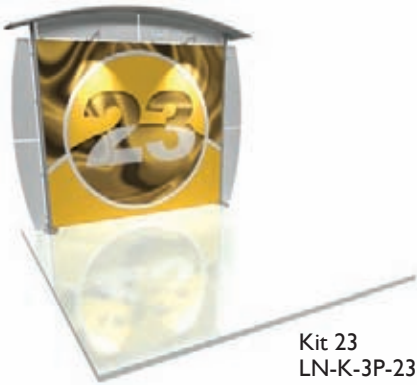

10' X 20' KITS

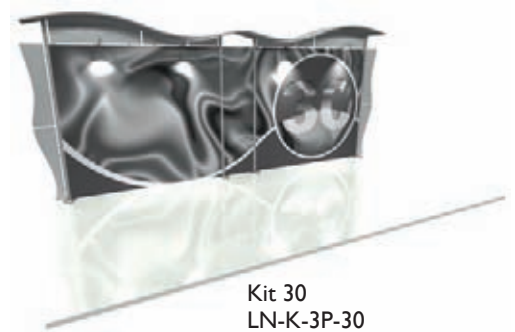
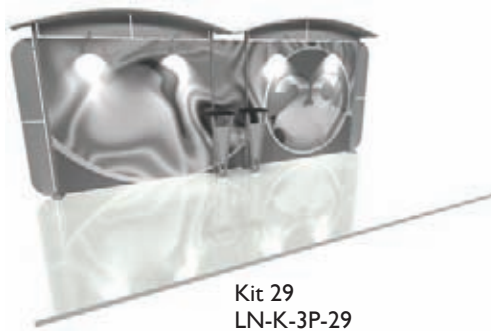
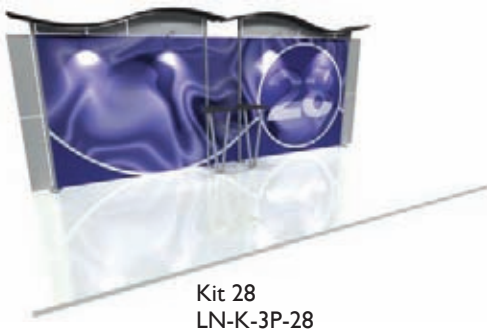
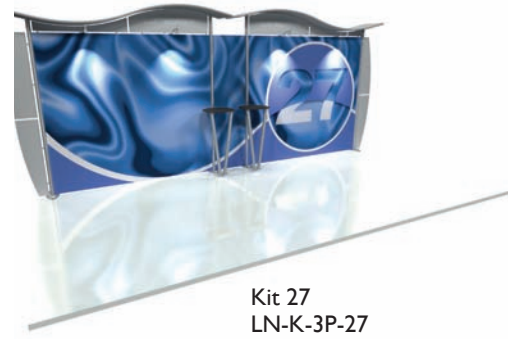
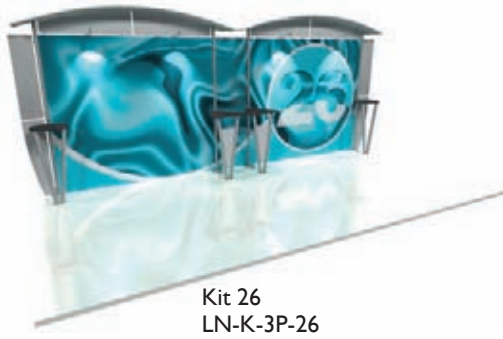

All Linear kits come with a lifetime warranty.



Kit 31
LN-K-31



Kit 32
LN-K-32

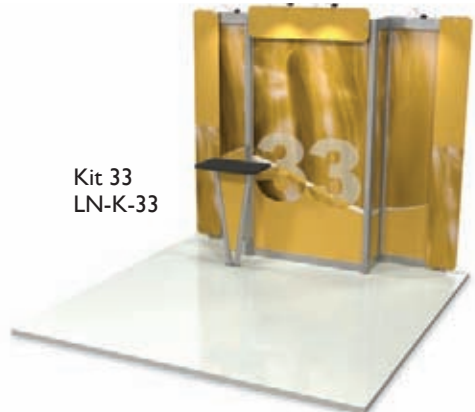

Kit 33
LN-K-33



Kit 34
LN-K-34



Kit 35
LN-K-35



Kit 36
LN-K-36



Kit 37
LN-K-37



Kit 38
LN-K-38



All Linear kits come with a lifetime warranty.



ATLANTIS 03

10'x10'
KIT

OR-K-ATL3

NEW

- truss backwalls offer a unique look
- shelving and monitor brackets allow for professional looking displays
- no tools necessary
- simple twist-lock construction
- new sturdy feet make these stand-alone backwalls possible



ATLANTIS 01
OR-K-ATL1

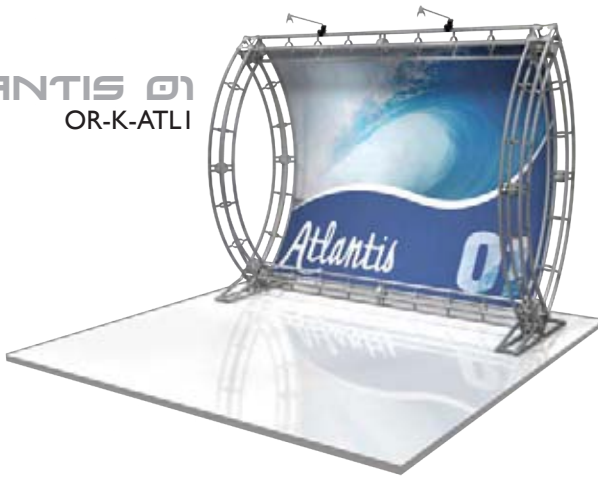

ATLANTIS 02
OR-K-ATL2

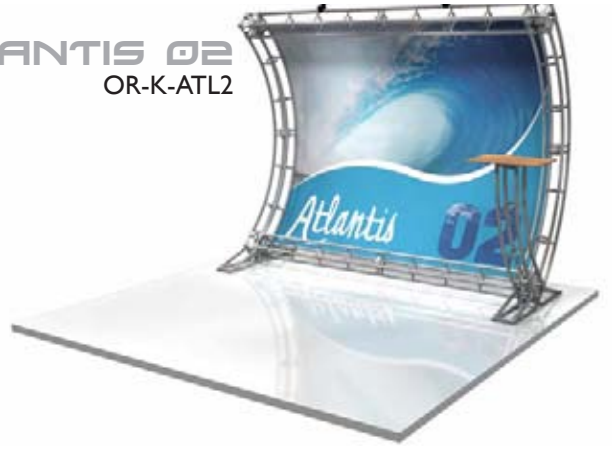

ATLANTIS 04
OR-K-ATL4

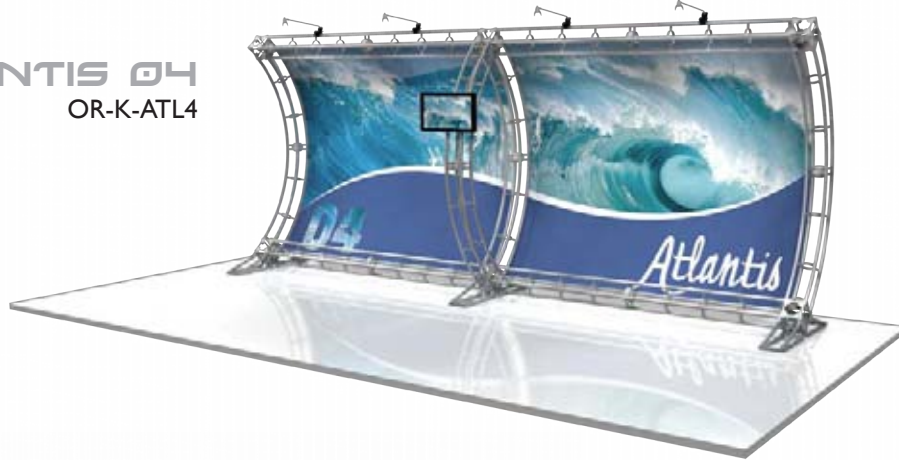

ATLANTIS 05
OR-K-ATL5

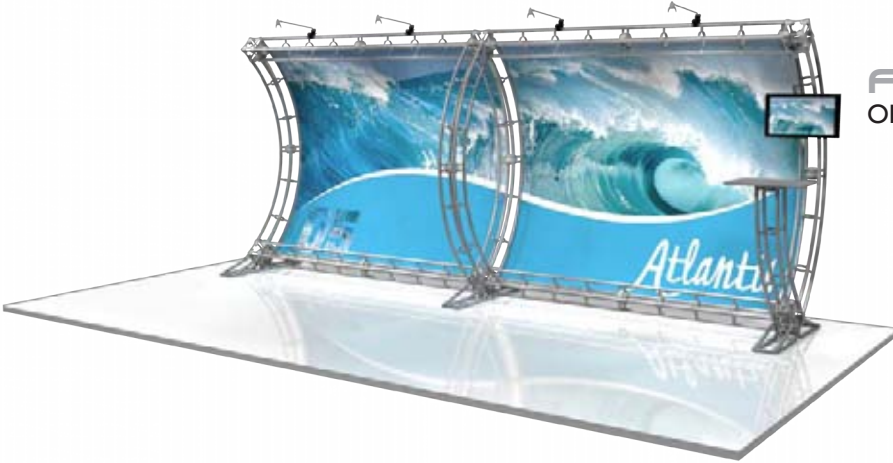

ATLANTIS 06
OR-K-ATL6

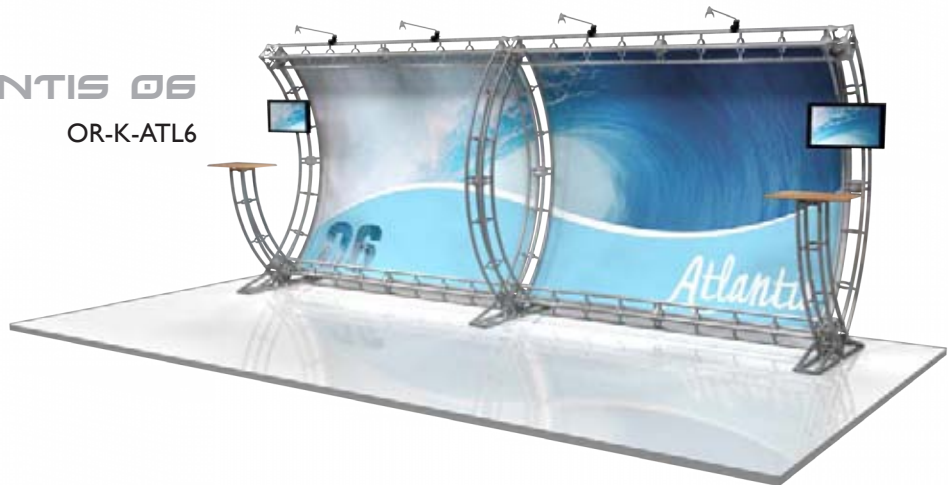

HERCULES

- truss backwalls offer a unique look
- shelving and monitor brackets allow for professional looking displays
- no tools necessary
- simple twist-lock construction
- new sturdy feet make these stand-alone backwalls possible



tables & shelves are available in your choice of finishes

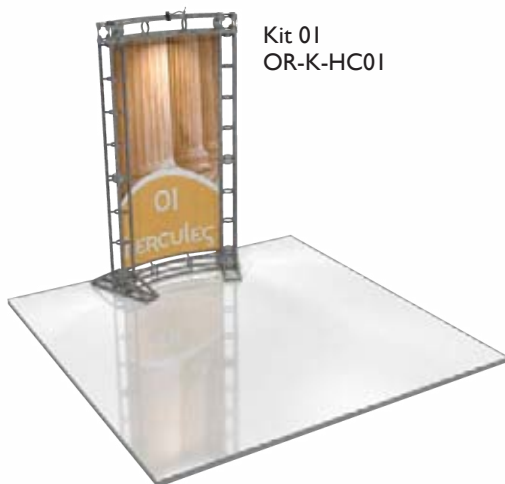
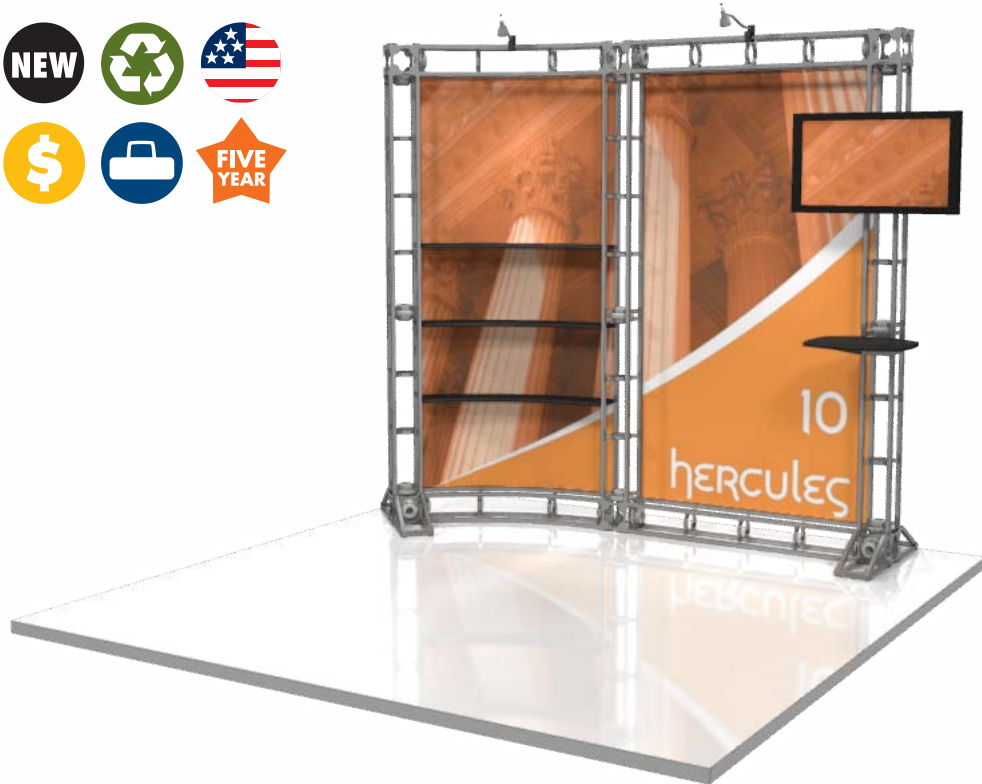
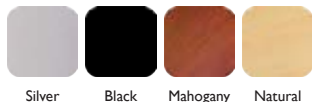

Kit 01
OR-K-HC01

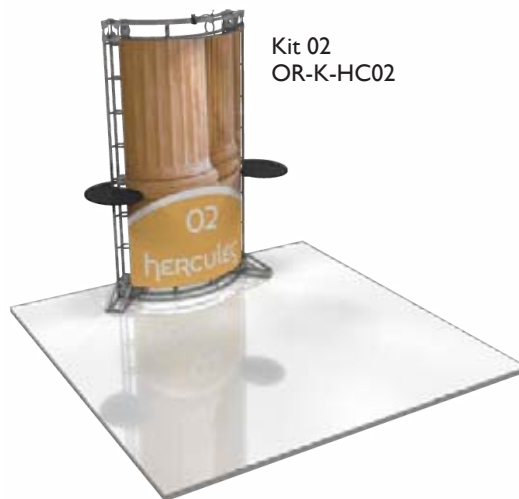

Kit 02
OR-K-HC02

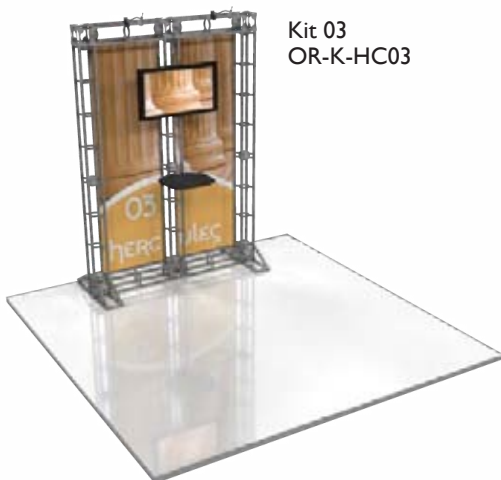

Kit 03
OR-K-HC03

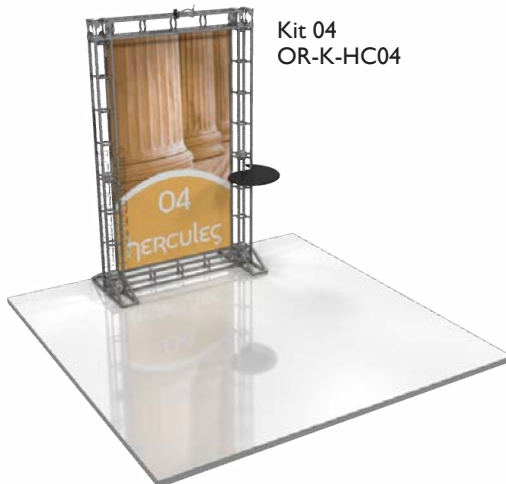

Kit 04
OR-K-HC04



Kit 05
OR-K-HC05

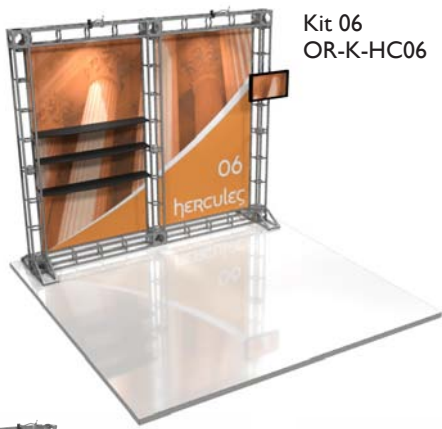

Kit 06
OR-K-HC06



Kit 07
OR-K-HC07

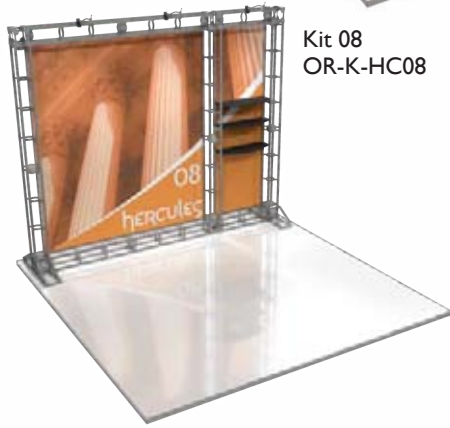

Kit 08
OR-K-HC08

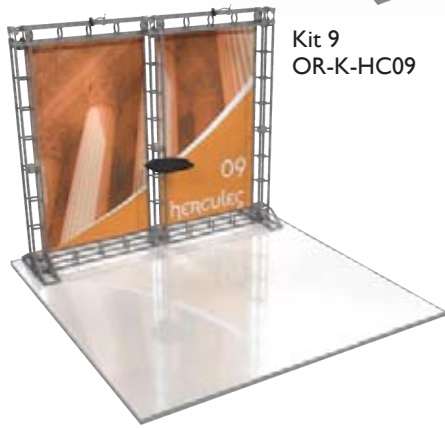

Kit 09
OR-K-HC09

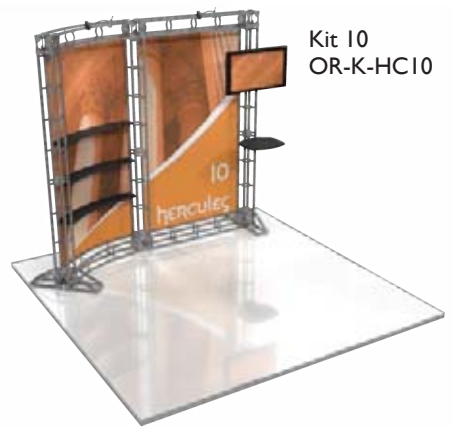

Kit 10
OR-K-HC10



Kit 11
OR-K-HC11



Kit 12
OR-K-HC12



Kit 13
OR-K-HC13



Kit 14
OR-K-HC14



Kit 15
OR-K-HC15



SIRIUS
10'x10' KIT OR-K-SR1 

The Orbital Express Truss System requires **NO TOOLS** for set up! Installation couldn't be easier, simply twist & lock. The specially designed connectors are simple to use, strong & secure. Our truss kits can be reconfigured in multiple ways using the same parts. Have a different exhibit for each show! We offer more than 40 professionally designed "off the shelf" kits for a variety of booth sizes and configurations. Each kit comes complete with all the parts, fixtures and fittings you need to create a successful exhibit, including (depending on the kit) low voltage spotlights and adjustable tabletops. All Orbital Express Truss kits are both an economical and eco-friendly exhibit choice. All kits include appropriate shipping cases.



ARA

10'x10'
KIT OR-K-AA1



VELA-2

10'x10'
KIT OR-K-VLI-2

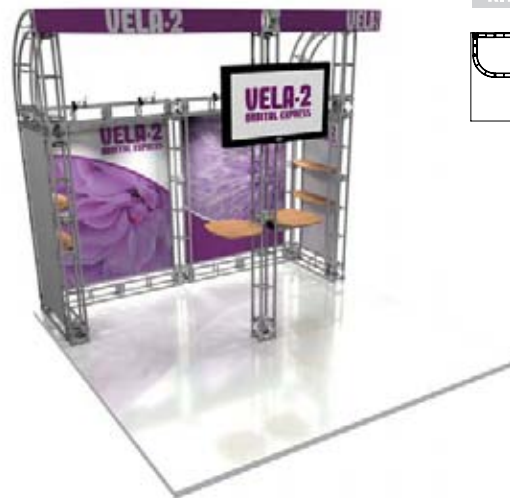

CETUS

10'x10'
KIT OR-K-CT1

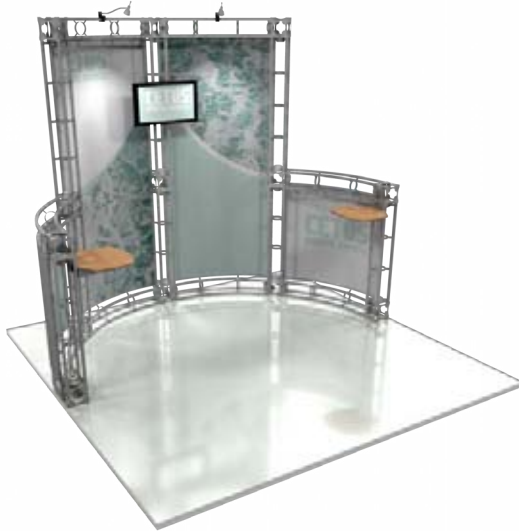

LYRA

10'x10'
KIT OR-K-LY1
corner kit

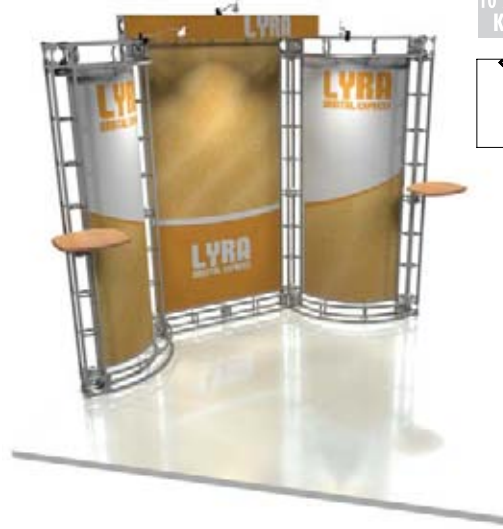

CARINA

10'x10'
KIT OR-K-CR1

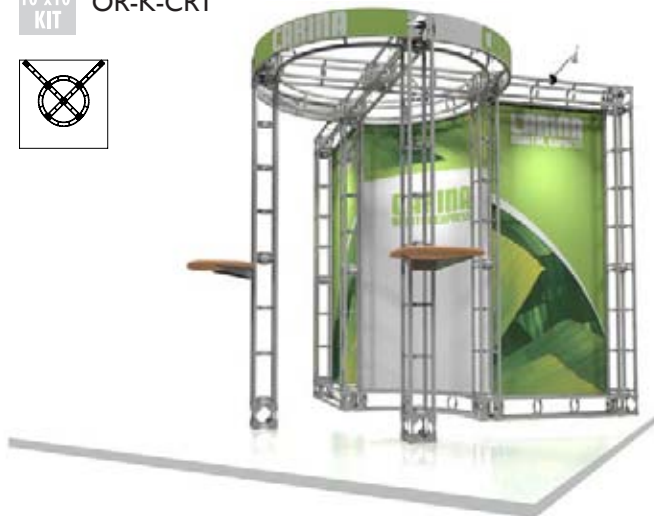

CASTOR

10'x10'
KIT OR-K-CS1

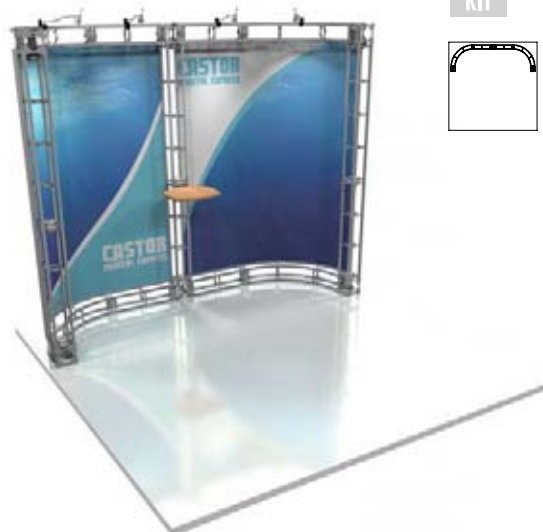

CYGNUS

10'x10' KIT OR-K-SYGI corner kit



PLUTO

10'x10' KIT OR-K-PLI

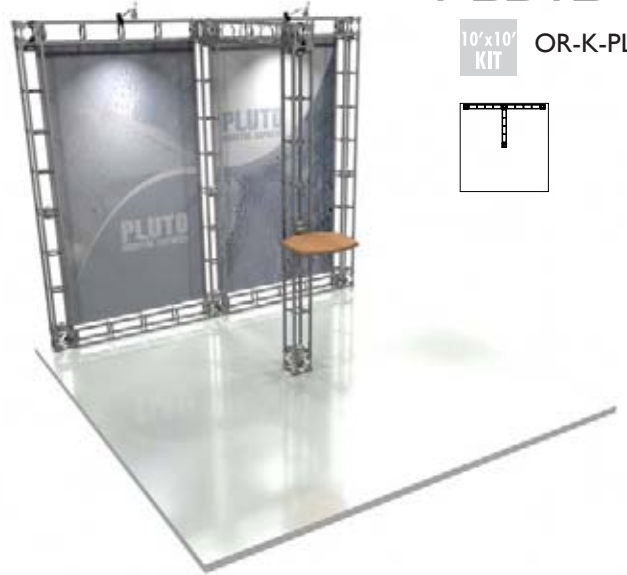
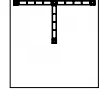

MERCURY

10'x10' KIT OR-K-MEI

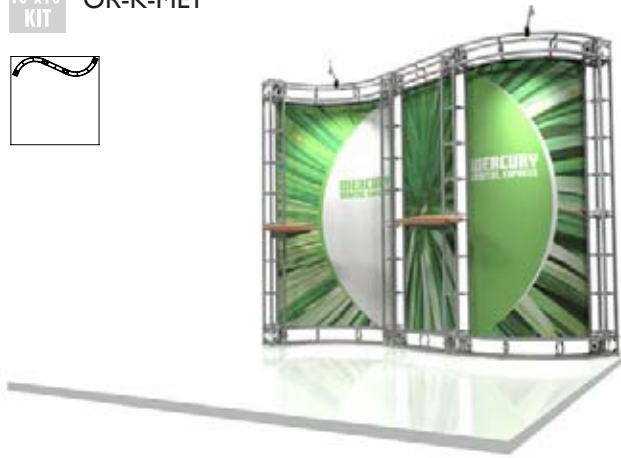

LYNX

10'x10' KIT OR-K-LXI

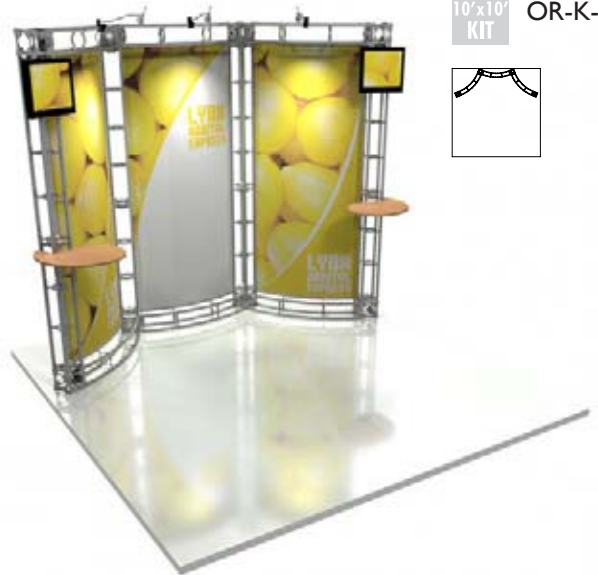
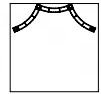

MARS

10'x10' KIT OR-K-MRI

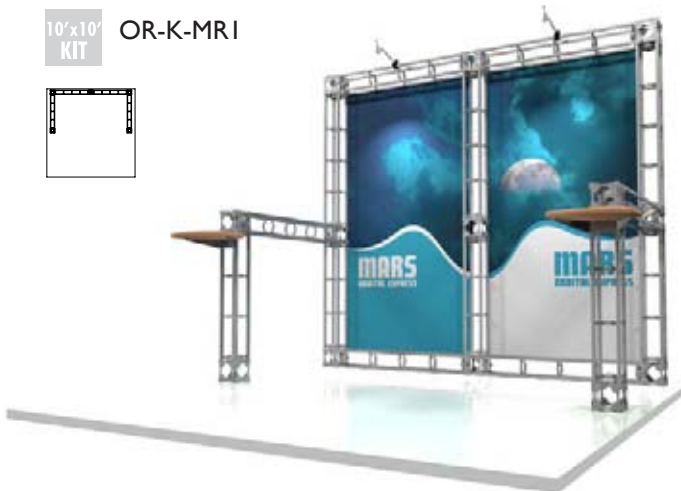

PAVO

10'x10' KIT OR-K-PAI

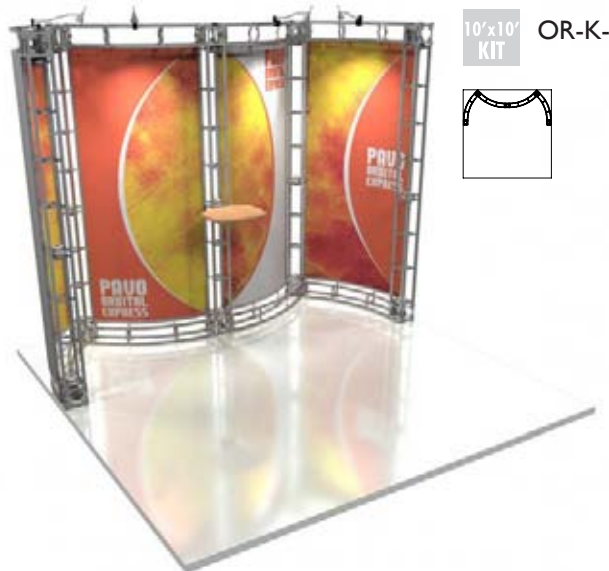
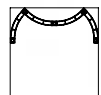

CEPHEUS-2

10'x20'
KIT

OR-K-CEI-2

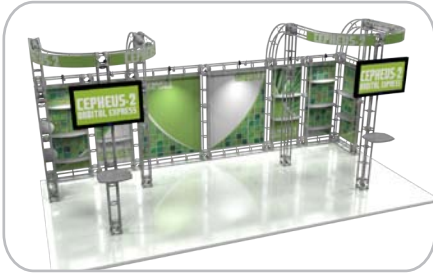
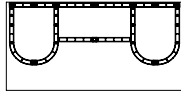

THETA

10'x20'
KIT

OR-K-THI

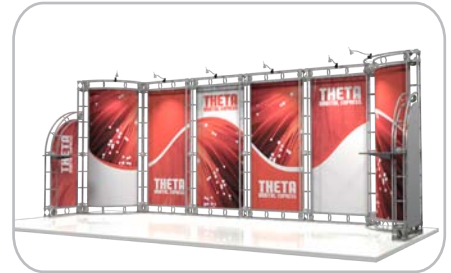

PICTOR

10'x20'
KIT

OR-K-PCI

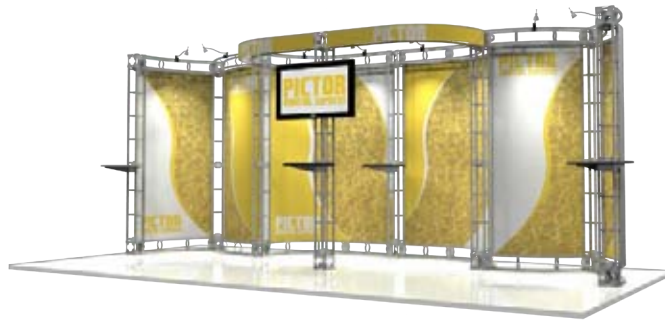
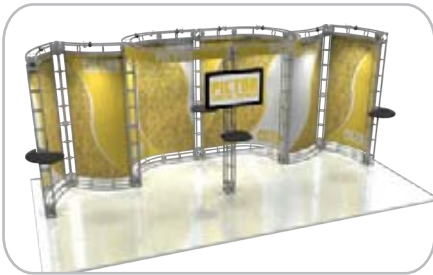
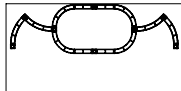

INDUS

10'x20'
KIT

OR-K-INI

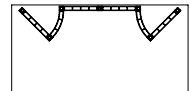

ANTARES

10'x20'
KIT OR-K-AT1

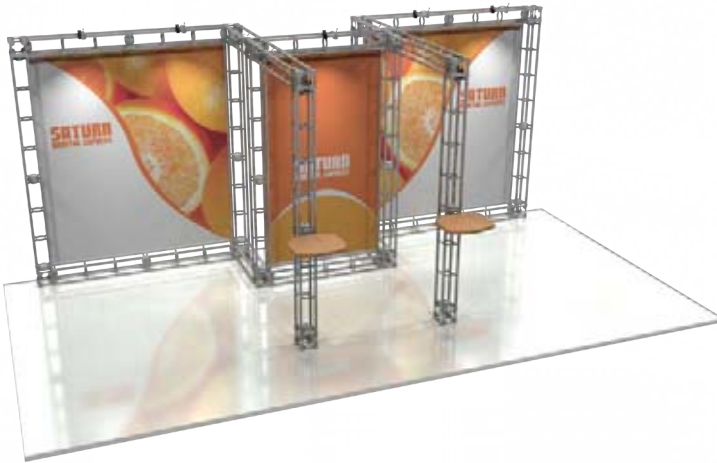
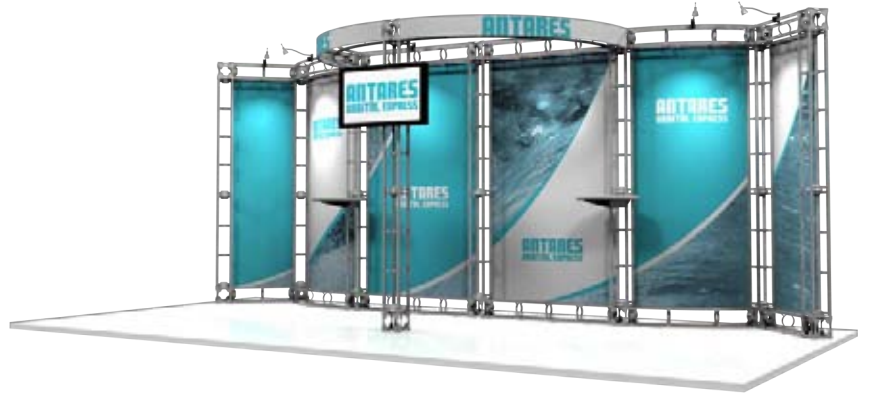
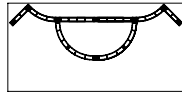

SATURN

10'x20'
KIT OR-K-SAI

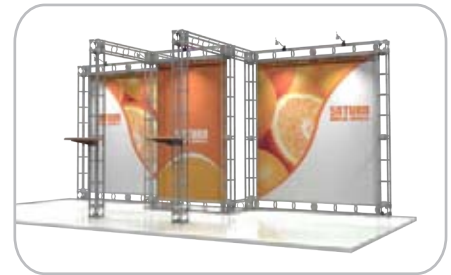
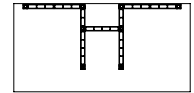

ELECTRA

10'x20'
KIT OR-K-ELI

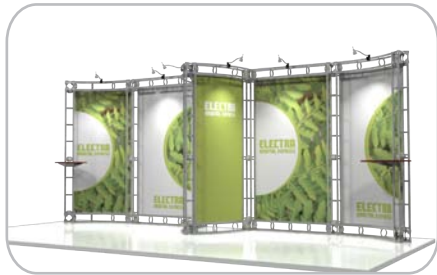
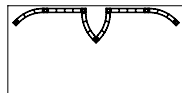

PHOENIX

10'x20'
KIT OR-K-PX1

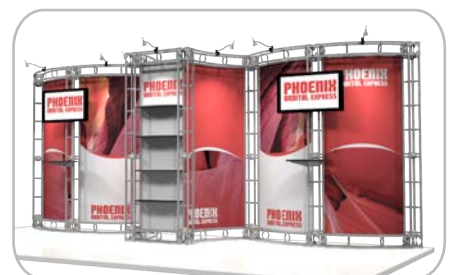
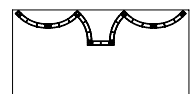

POLARIS

10'x20'
KIT

OR-K-PR I

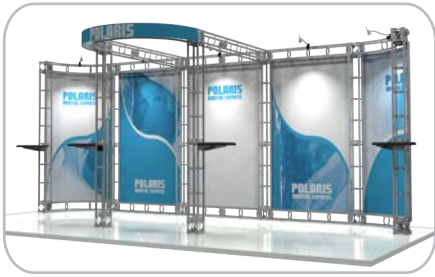
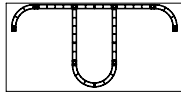

OMICRON

10'x20'
KIT

OR-K-OMI

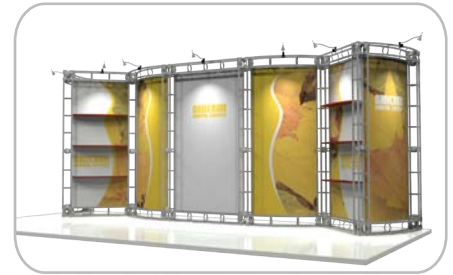
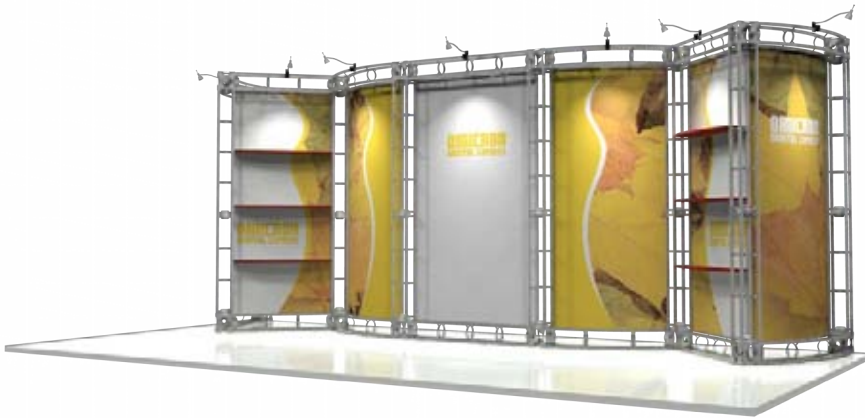
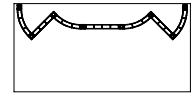

ANDROMEDA

10'x20'
KIT

OR-K-ADI

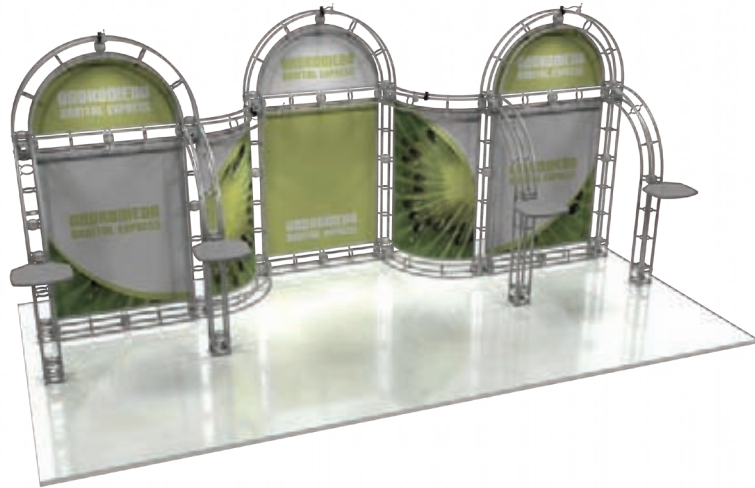
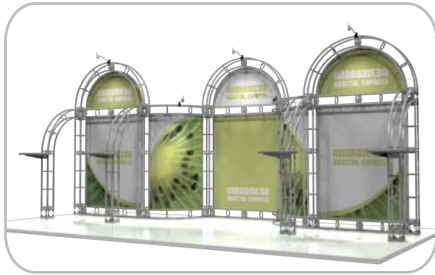
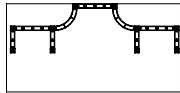

ARCTURUS

10'x20'
KIT

OR-K-ARI

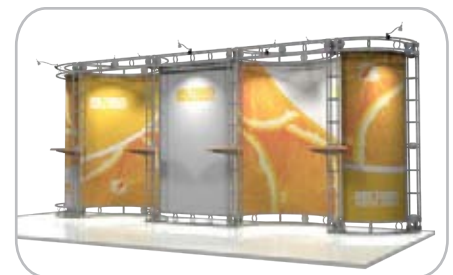
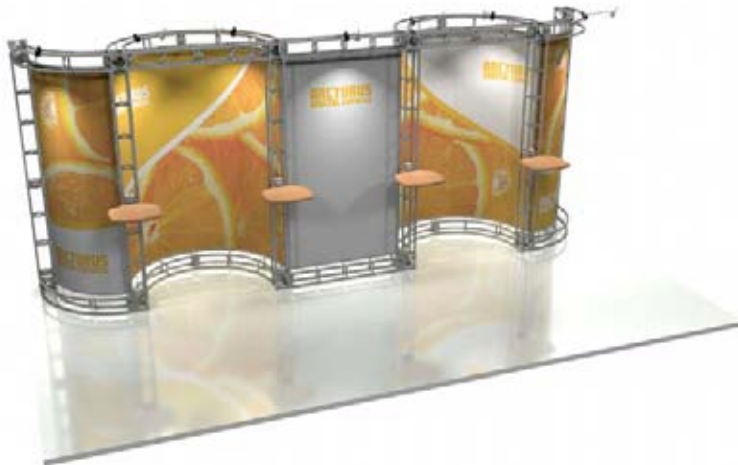
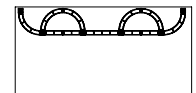

VENUS

10'x20'
KIT OR-K-VEI

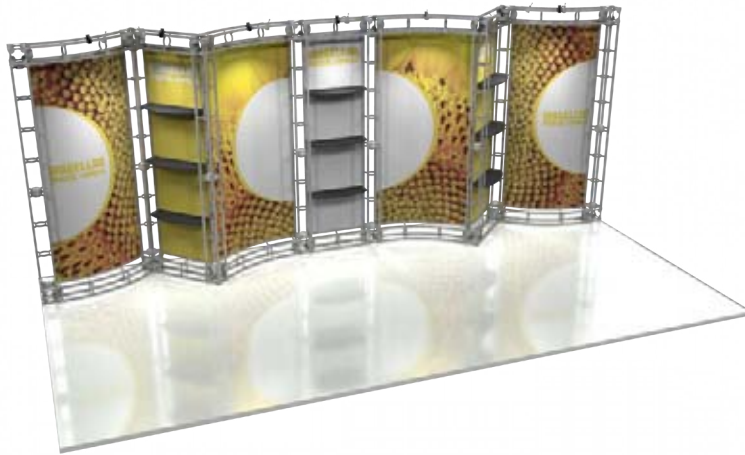
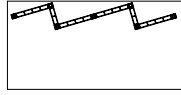

MAGELLAN

10'x20'
KIT OR-K-MGI

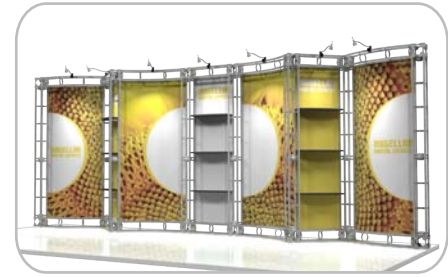
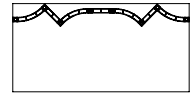

HYDRUS

10'x20'
KIT OR-K-HDI

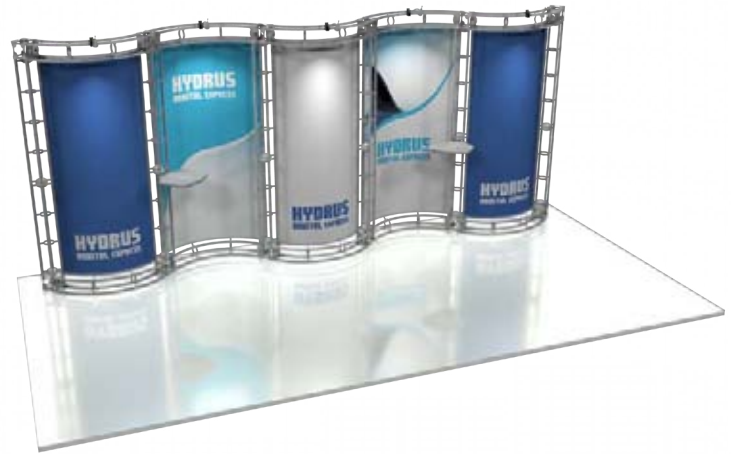
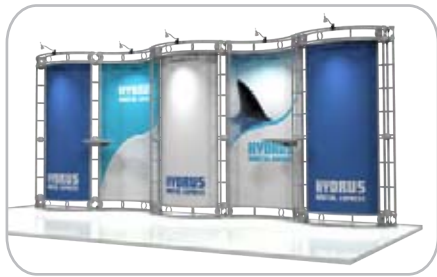
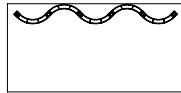

LED

20'x20'
KIT OR-K-LEI

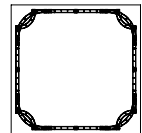

DORADO

20'x20'
KIT OR-K-DOI

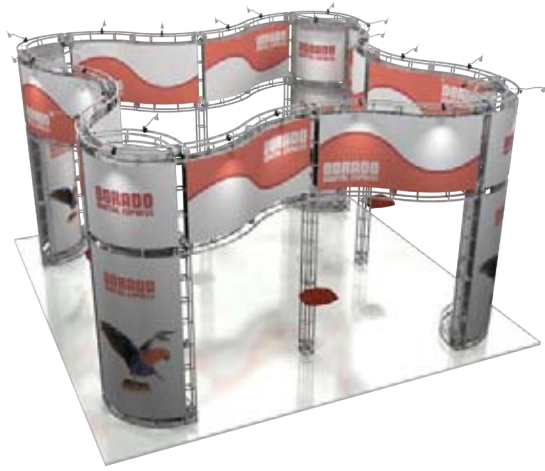
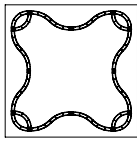

CORVUS

20'x20'
KIT OR-K-CVI

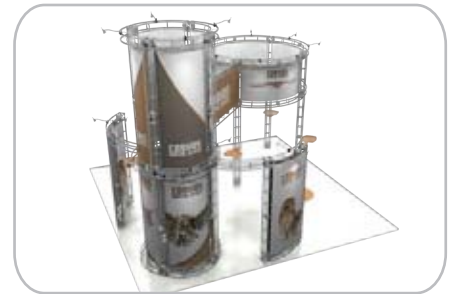
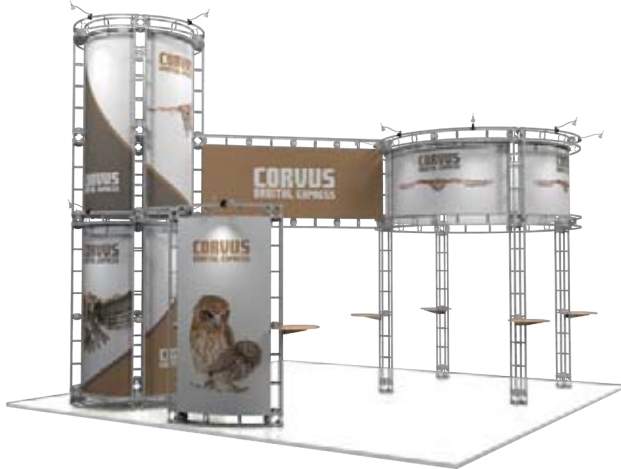
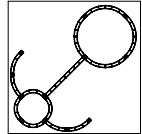

CENTAURUS

20'x20'
KIT OR-K-CNI

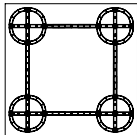

NEPTUNE

20'x20'
KIT OR-K-NPI

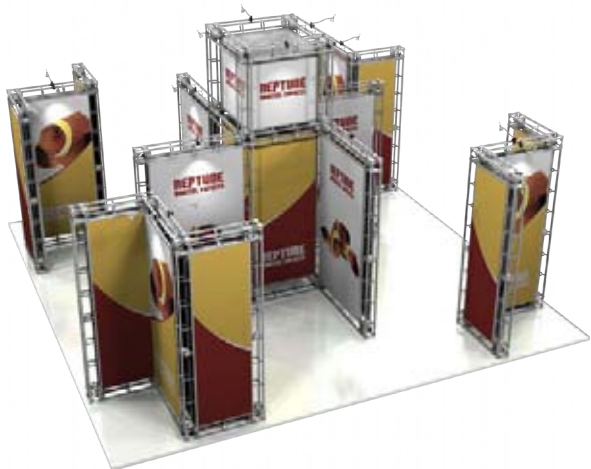
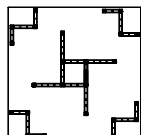

tower also sold separately: OR-K-NPT

TUCANA

20'x20' KIT OR-K-TUI

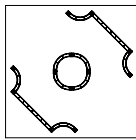

tower also sold separately: OR-K-TUT



ORION

20'x20' KIT OR-K-ORI

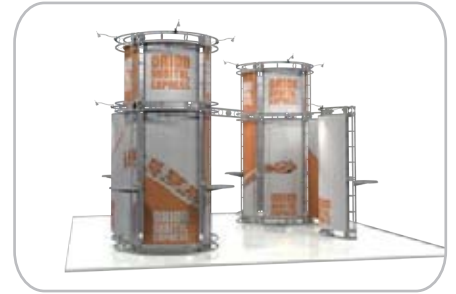
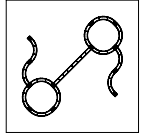

VEGA

20'x20' KIT OR-K-VGI

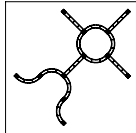

ALTAIR

20'x20' KIT OR-K-ALI

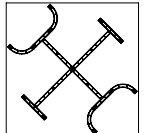



CANIS

20'x20'
KIT

OR-K-CAI

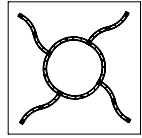

DRACO

20'x20'
KIT

OR-K-DRI

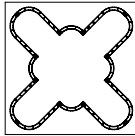

JUPITER

20'x20'
KIT

OR-K-JPI

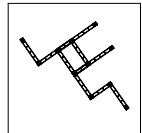

OCT

- large, round, general purpose freight case
- designed to handle national & international exhibit freight shipments
- offers maximum protection for your exhibit materials
- stackable and can be moved using the built-in castors or with a forklift
- shipping size= 50" w x 43" h x 47" d



OCF

- offers the same features and benefits of the OCT in a rectangular shape
- shipping size= 51" w x 22" h x 38" d



TRUSS COUNTERS

- several attractive designs to chose from
- sleek plex top option available
- 4 tabletop colors available
- no tools required for assembly



shown with optional front graphic panel

tops are available in your choice of finishes



Silver Black Mahogany Natural



shown with optional plex stand-off (tool required)

plastic connectors make it easy to assemble



plex accent attaches with screw-on stand-offs

RECTANGLE



OR-TC01 rectangle - standard



OR-TC01-P rectangle - with plex stand-off and internal shelf

OVAL



OR-TC02 oval - standard



OR-TC02-P oval - with plex stand-off and internal shelf

RACETRACK



OR-TC03 racetrack - standard



OR-TC03-P racetrack - with plex stand-off and internal shelf

CURVE



OR-TC04 curve - standard



OR-TC04-P curve - with plex stand-off and internal shelf

TRUSS PODIUMS

- easy to assemble
- perfectly complements your Orbital truss display
- your choice of 4 tabletop colors
- 5 shapes to chose from
- plex stand-off option available on all kits



tops are available in your choice of finishes

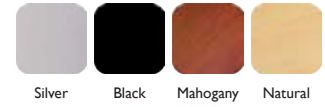

square shown with plex option
OR-P05-P



circle
OR-P01



teardrop
OR-P02



eye
OR-P03



racetrack
OR-P04



square
OR-P05

LAMINATE TABLETOPS



NATURAL



OR-TBL-WD

MAHOGANY



OR-TBL-DWD

SILVER



OR-TBL-S

BLACK

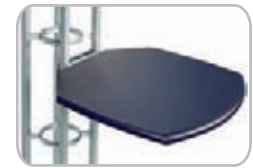

OR-TBL-B



right facing: OR-TBL2-R-WD
left facing: OR-TBL-L-WD



right facing: OR-TBL2-R-DWD
left facing: OR-TBL2-L-DWD



right facing: OR-TBL2-R-S
left facing: OR-TBL2-L-S

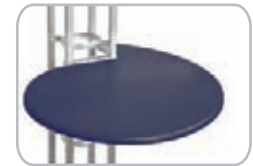

right facing: OR-TBL2-R-B
left facing: OR-TBL2-L-B

LIT RACK

OR-STG



- 10 pocket clamp on literature rack
- sleek design
- note: rack may not fit into the standard kit packaging solution/ molded case

OPTI MOUNT

- adjustable angles up to 30°



OR-LCD-1-S

Opti-Mount 1
15"-30" LCD
max weight=
30 lbs



OR-LCD-3-S

Opti-Mount 3
30"-50" LCD
max weight=
130 lbs

INTERNAL SHELVING

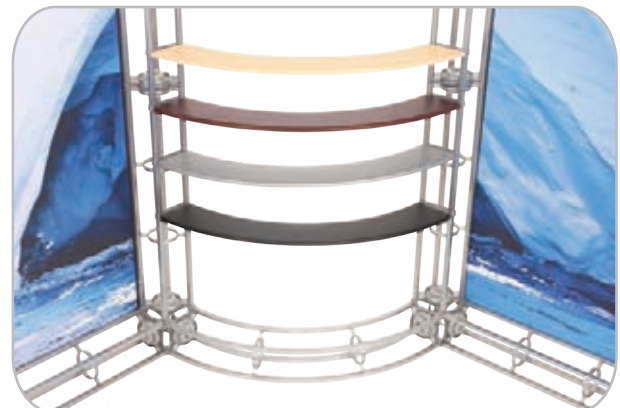

- available in all 4 finishes (light wood, mahogany, silver & black)
- 24" straight span, 36" straight span, and 46" straight span shelves available
- 45° curved and 90° curved shelves (shown above)





ZEDUP 1

black: ZD-I-B
silver: ZD-I-S



- 6 pocket rack
- can be stored or shipped loaded with literature

hard case upgrade:
black: ZD-I-HC-B
silver: ZD-I-HC-S



ZEDUP LITE

silver: ZD-LITE



- 6 pocket rack
- collapsible
- lightweight version of the ZedUp
- constructed from aluminum & plastic for reduced weight



ILLUSION



Illusion 1 single width
black: IL-1-B, silver: IL-1-S
Illusion 2 double width
black: IL-2-B, silver: IL-2-S

- fast-folding cantilever rack
- 4 front facing pockets



10 UP

black: 10UP-B



- strong & stable
- 10 pockets
- packs flat



VICTORY

black: VIC-B
silver: VIC-S



- slim, modular, snap-together design



TITAN

black: TITN-B

- modular design
- heavy duty
- 8 pocket
- packs in 3 separate parts for reduced shipping size



INNOVATE

black: INN-B
silver: INN-S



- modular design
- 10 pockets
- packs in 3 separate parts for reduced shipping size





LUMINA 1

silk black: LUM-1-B
chrome: LUM-1-C

- low voltage 50 watt spotlight
- "goose neck" arm
- mounts horizontally

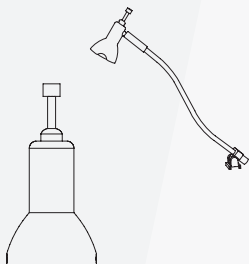

LUMINA 2

LUM-2

- low voltage 35 watt slender spotlight
- mounts to a vertical pole
- brushed stainless steel finish

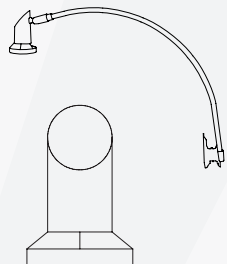

LUMINA 3

LUM-3

- low voltage 50 watt
- spotlight, chrome with a black head
- telescopic arm
- extends from 7"-22" long

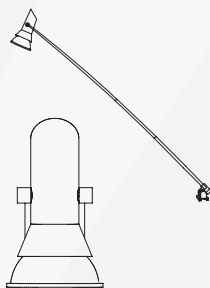

LUMINA 5

LUM-5

- low voltage 50 watt spotlight
- deluxe chrome head
- telescopic arm
- extends from 7"-22" long

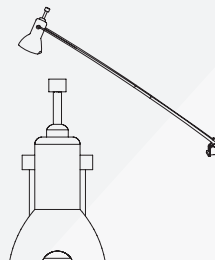

LUMINA 6

LUM-6

- low voltage, 50 watt spotlight
- stylish curved twin arms
- silk black only

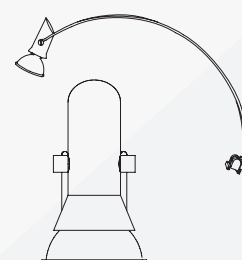

LUMINA 7

LUM-7

- incandescent 110 volt fixture
- dovetail mount
- 45 watt incandescent bulb included
- silk black only

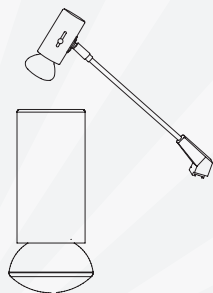

LUMINA 8

silk black: LUM-8-B
painted silver: LUM-8-C

- 12 volt spotlight with straight arm & adjustable head
- includes 110 volt UL approved transformer, 50 watt bulb & universal fittings kit
- 17" (431.8 mm) long from end to end

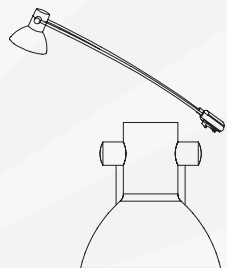

LUMINA 200

LUM-200 ORL

- 110 volt ETL approved wall washer floodlight with a straight arm & adjustable head
- light includes 200 watt halogen bulb
- 19.5" (495.3 mm) long from end to end
- silk black finish

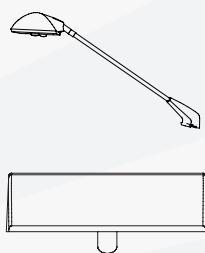

LUMINA 200 LED

LUM-LED-ORL-B

- LED version of the Lumina 200 floodlight
- 1400 Ma, 12VDC
- LED rated for 20,000 continuous hours

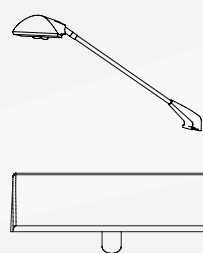

LUMINA SPARE BULB KIT

LUM-BULB
- (2) 50 watt low voltage spare bulbs in a padded, protective EVA formed case



UNIVERSAL LIGHT CLAMP KIT

UNI-LT-CLP
- comes standard with the Lumina 1, 3, 4, 5, 6, 8, 9, 10, 11, 12, 13 and allows our lights to fit a majority of banners, truss & panel kits

LED BULB OPTION

MR11: LUM-LV-LED-BLB11
- a green solution for Lumina 2
- 3 watt LED bulb

MR16: LUM-LV-LED-BLB16
- a green solution for Lumina 1, 3, 4, 5, 6, 8, 10, 11, 12, & 13
- 5 watt LED bulb



MR11

MR16



All our lighting options come with a one year warranty.

OCA2 **NEW**
OCA2

- attaches to the OCFM or OCHM for easy transport of accessories
- ideal for lights and accessories associated to other products
- secure straps help to assure case will remain closed during transport



OC-HOP **NEW**
OC-HOP

- ideal for Hopup backwall displays
- built-in handle and wheels for easy transport



OCM **NEW** 
OCM

- black LLDPE Polyethelene case designed for LCD monitors
- built in dry erase board to label contents and location
- fits 37" - 47" screens
- made from 100% recycled materials
- 40"h x 54"w x 16"d (with wheels)
- 69lbs, empty weight
- includes 3" casters with rubber wheels
- must be shipped freight



OCHM **NEW**
OCHM

- interlocking surface to enable two cases to be transported together
- maximum case depth= 8" allowing up to 8 flat panels per case



OCH
OCH

- blow molded case for exhibits, graphics & accessories
- reliable built in wheels
- easy to grip molded handles
- secure reinforced straps help to assure case will remain closed during transport
- strong yet lightweight



OCH2 **NEW**
OCH2

- heavy-duty shipping and storage case
- ideal for Linear hybrid displays
- built in wheels and handle
- secure reinforced straps help to assure case will remain closed during transport



OCFM **NEW**
OCFM

- interlocking surface to enable two cases to be transported together
- maximum case depth= 8" allowing up to 8 flat panels per case



OCF2 **NEW**
OCF2

- molded stackable shipping crate 18" deep
- heavy-duty roller bearing recessed in bridge of case
- holds 18 layers of flat panels in horizontal direction



LUMINA SPT CASE
SPT-CASE

- EVA semi-rigid lighting case
- foam-lined padded compartments
- holds two Lumina lights & power supply



LUMINA FLD CASE
FLD-CASE

- EVA semi-rigid lighting case
- foam-lined padded compartments
- stores & transports two lights
- designed for use with Lumina models 1-5



OASIS **ONE YEAR**

- highly portable
- three arm collapsible bag dispenser
- shiny silver finish



STEP STOOL **ONE YEAR**

- sturdy EZ FOLDZ step stool
- 300 lb capacity
- folds flat for storage and transport
- red only



WEDGE **FIVE YEAR**

- simple to use sign support
- combine multiple units for longer and taller displays
- graphic size is variable
- black only
- graphics not included



application shown uses multiple units

BREEZE

BREZ-1-S: 8.375" w x 11.25" h
BREZ-2: 11" w x 17" h

- retractable tabletop stand
- ideal for custom calendars & other promotional banners



VORT-X MINI

red: VTX-MC **90 DAY**
blue: VTX-MC-BL

- quick & simple to assemble
- ideal for retail/POP use
- sold in packs of 2
- visual area= 12" w x 16.5" h



SIGNATURE

SIG-3 (3 pockets): 4.25" x 11"
SIG-4 (3 pockets): 4.25" x 11"

- tabletop literature dispensers
- sold in packs of 2



TABLE ACE

TB-ACE-1: 6" w x 12" h
TB-ACE-2: 6" w x 24" h
TB-ACE-3: 12" w x 24" h

- mini tabletop banner stands
- sold in packs of 3
- black only



TRAPPA POSTER FRAME

FIVE YEAR

- silver anodized finish w/precision mitered corners
- snaps open for quick & easy graphic changes
- features spring loaded aluminum extrusions mounted to a high-impact polystyrene backer
- available in a wide range of standard sizes & includes a clear anti-glare lens



APEX

APEX

ONE YEAR

- double-sided plastic a-frame
- can be printed directly on the plastic for a smooth look
- for indoor or outdoor use



SYNERGY

SYN-2-1

ONE YEAR

- double-sided aluminum a-frame
- snap edges for quick graphic changes
- silver anodized finish



All display additions on this page are a recyclable choice.

BROUGHT TO YOU BY:

www.exhibitors-handbook.com

**America's
Favorite
Tradeshow
Supplier**

