

# LINEAR 25

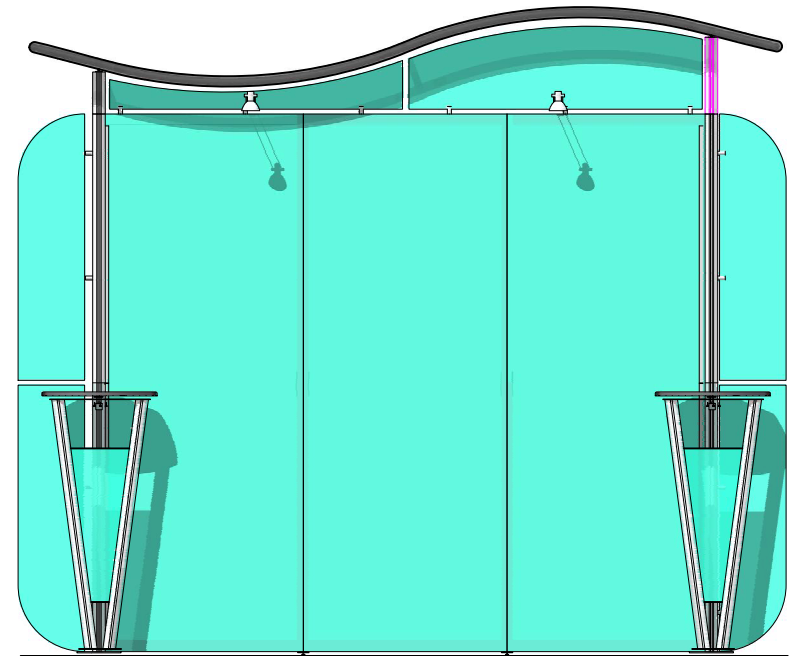

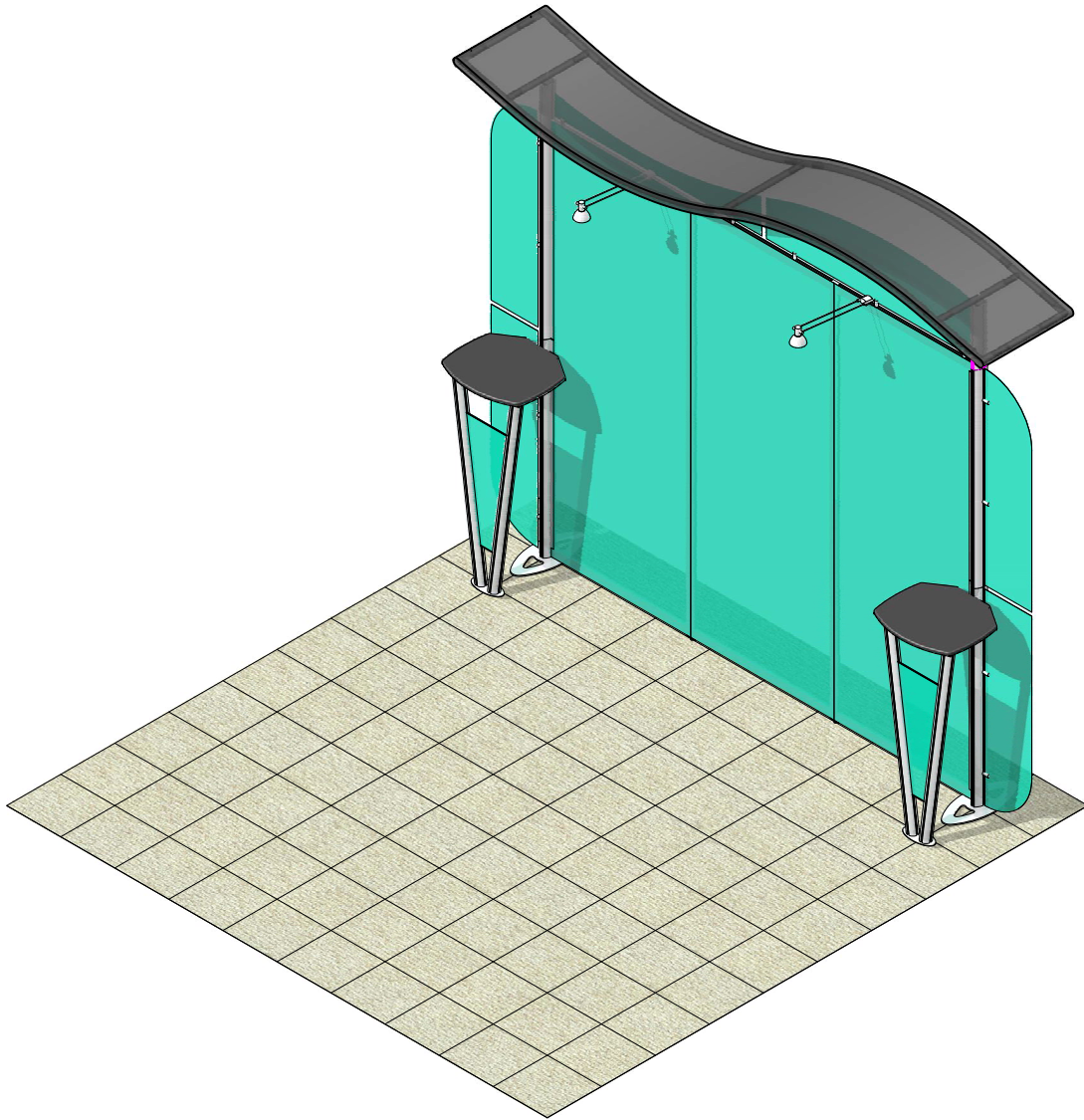

Code	#	Description
L3	3	HORIZONTAL GRAPHIC BAR
L4	2	VERTICAL GRAPHIC BAR WITH CENTER FOOT POST
L1	2	BOTTOM HALF UPRIGHT

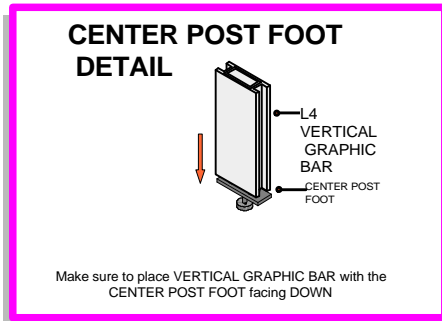
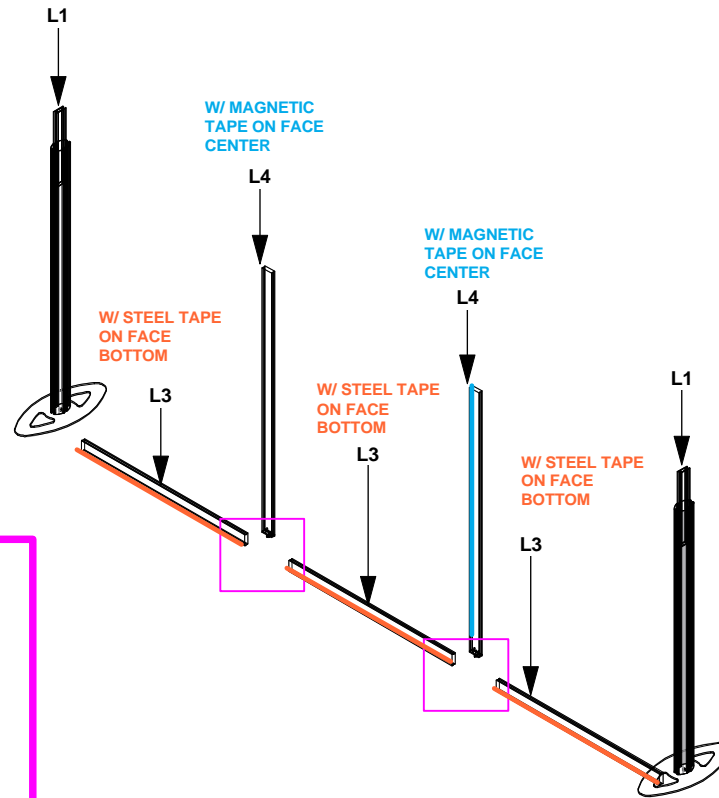
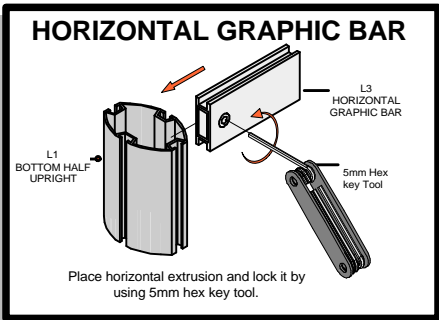
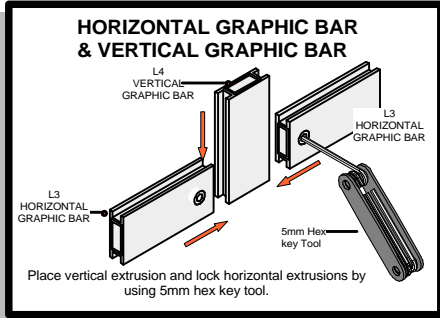
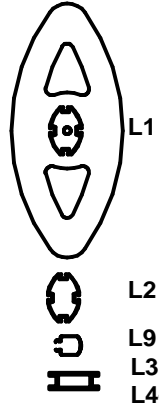

LINEAR 25



Code	#	Description
JOINER BAR	4	JOINER BAR
CORNER LOCK	2	CORNER LOCK

**CORNER LOCK DETAIL**

CORNER LOCK

Slide CORNER LOCK into front channel.

**JOINER BAR DETAIL**

SET SCREW

VERTICAL GRAPHIC BAR

Slide the JOINER BAR the tracks of one extrusion. Then push the two extrusions together.

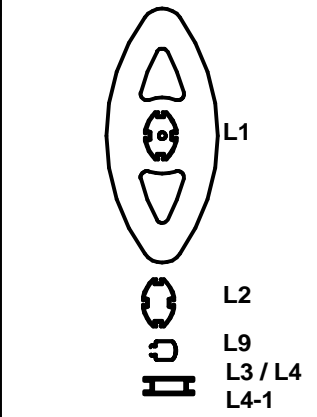
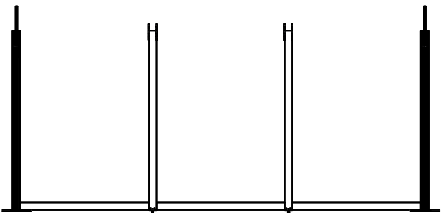
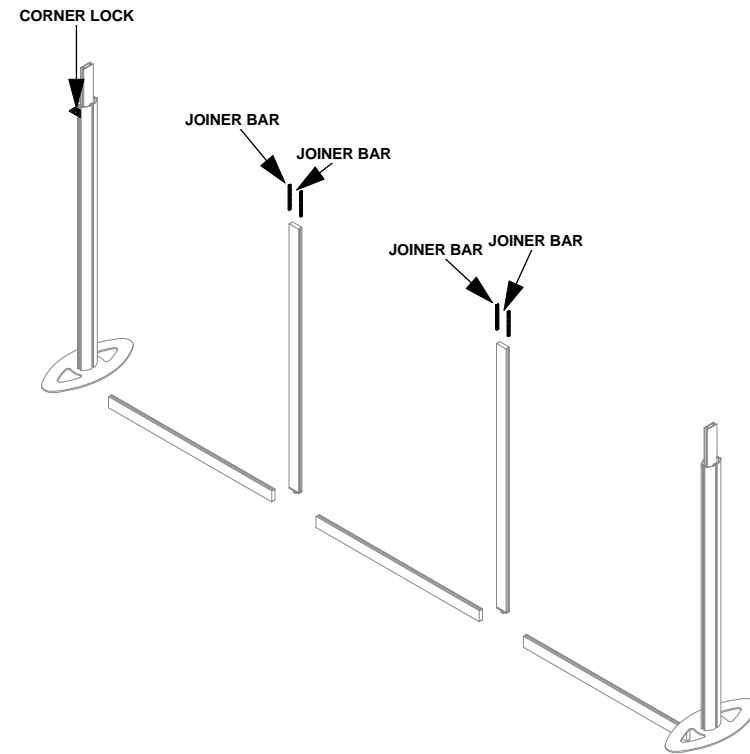

**LINEAR 25**



Code	#	Description
L2	2	TOP HALF UPRIGHT
L3	3	HORIZONTAL GRAPHIC BAR
L4-1	2	VERTICAL GRAPHIC BAR
L9	4	GRAPHICS MOUNTING BAR

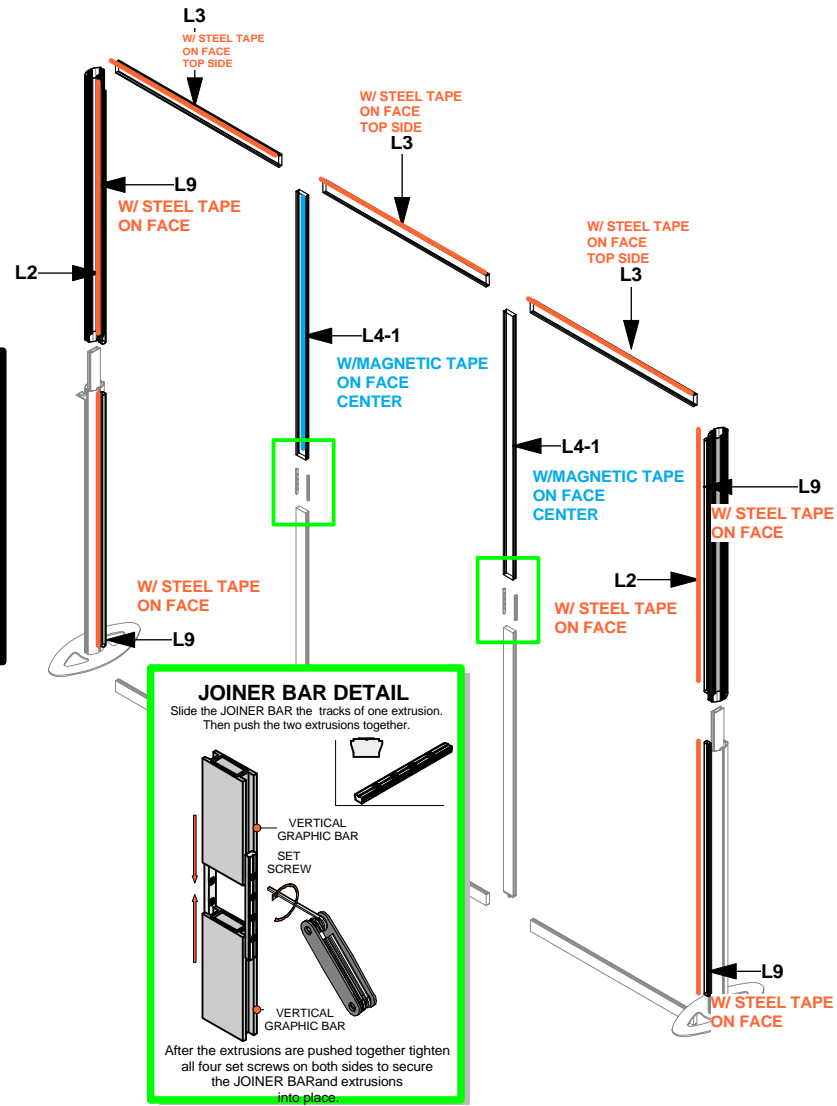
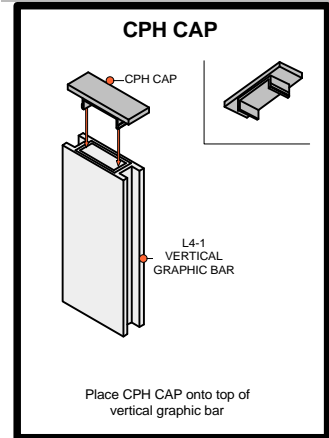
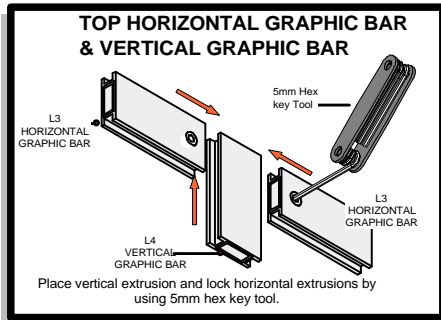
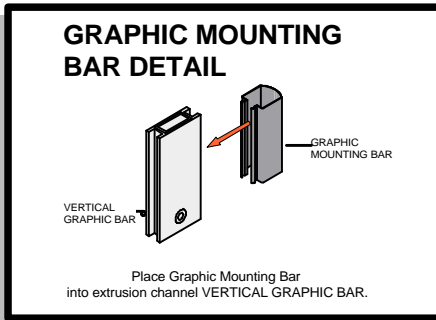
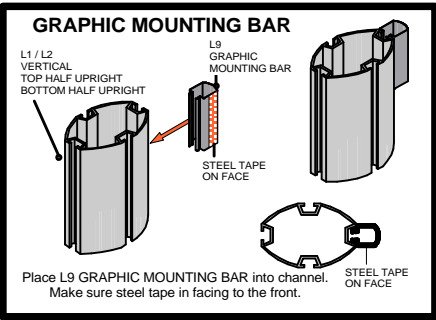
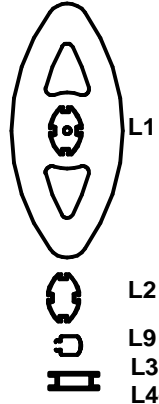

LINEAR 25



Code	#	Description
L5-2	1	GRAPHICS
L5-1	1	GRAPHICS
L5-3	1	GRAPHICS

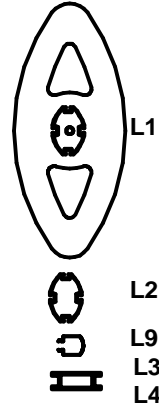
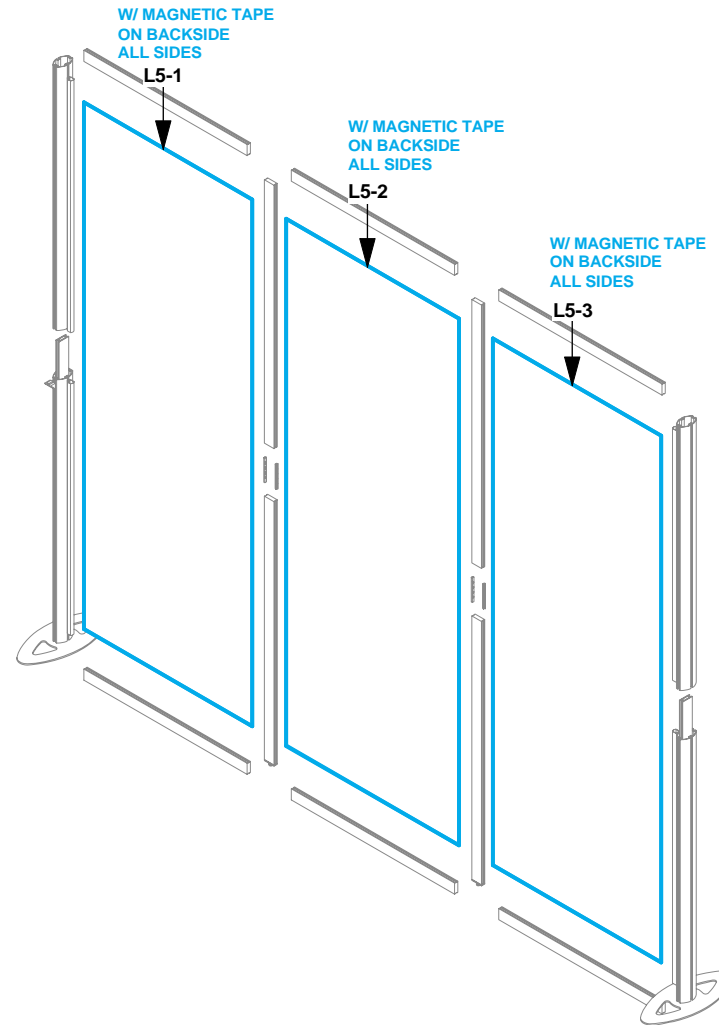
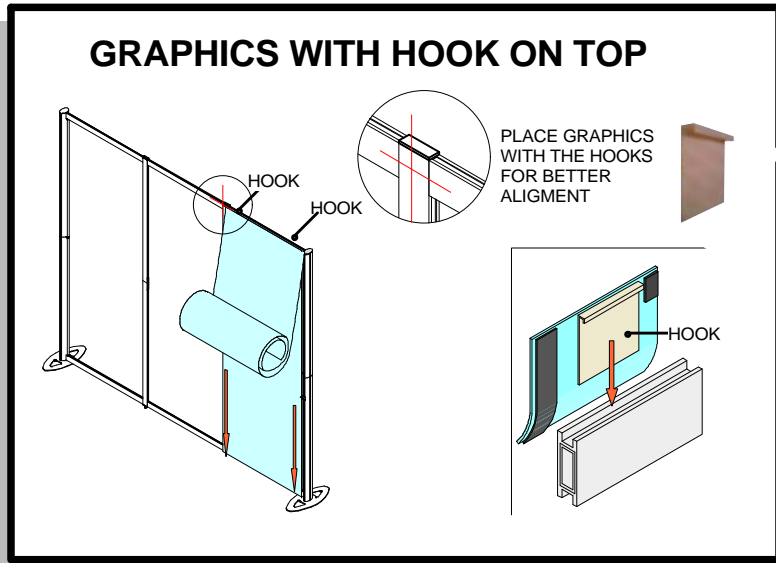

**LINEAR 25**

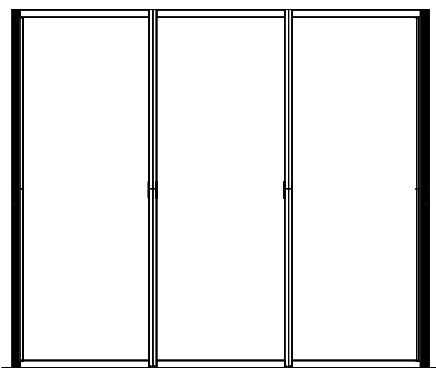

Code	#	Description
LV3 LIGHT	2	GREY SKINNY LIGHT WITH OSRAM TITAN 50W LA

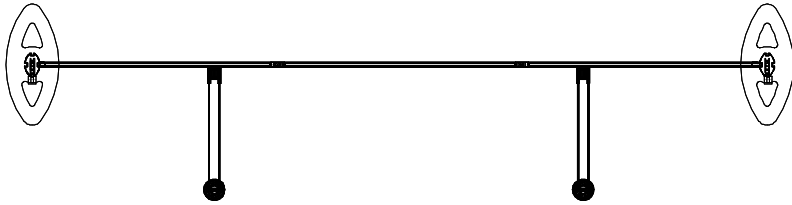

**LIGHT DETAIL**

LIGHT CLIP  
HORIZONTAL GRAPHIC BAR  
L10 LIGHT  
LV1 LIGHT  
LV3 LIGHT  
LIGHT CLIP

Slide the light clip into the channel at an angle and then gently lower down. Then slide the LV3 Light onto the light clip.

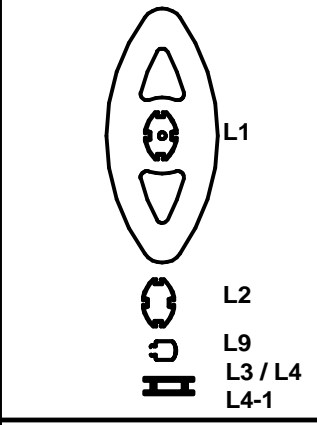
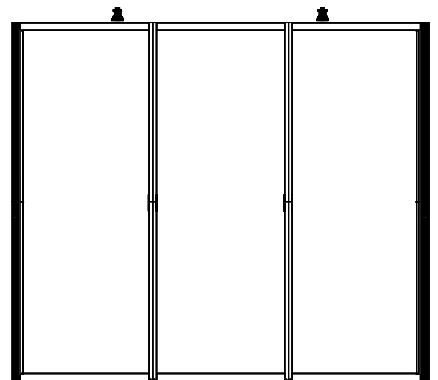
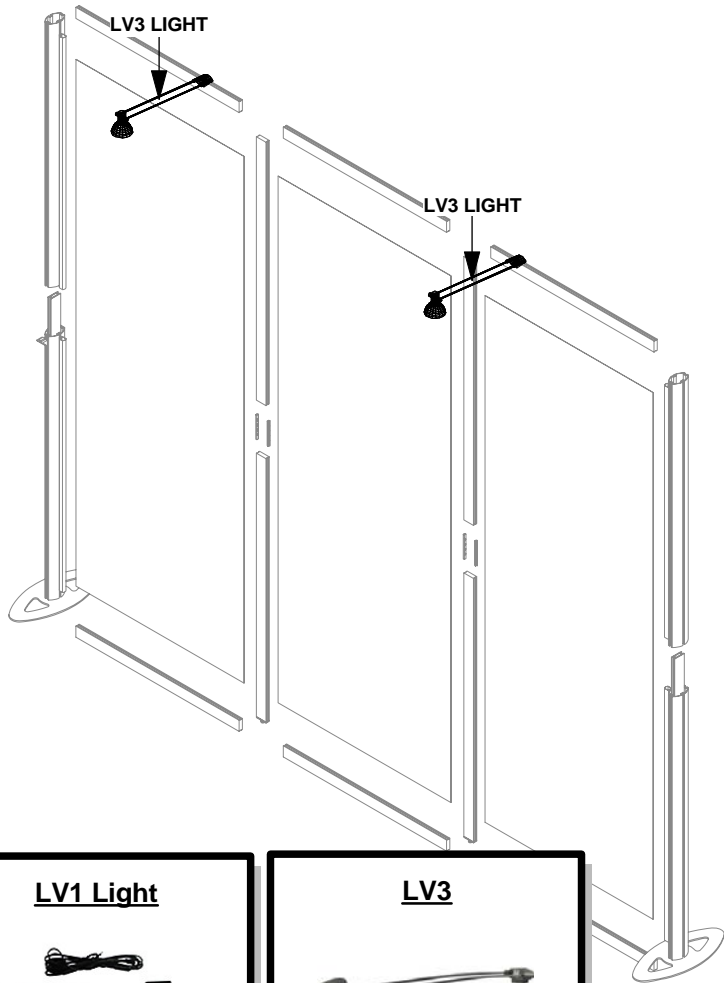

**LINEAR 25**

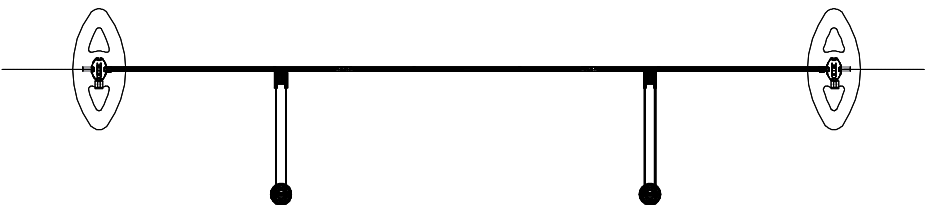

Code	#	Description
CKAPS	14	STANDOFFS
L11-4	1	GRAPHICS
L11-3	1	GRAPHICS
L11-6	1	GRAPHICS
L11-2	1	GRAPHICS
L11-1	1	GRAPHICS
L11-7	1	GRAPHICS

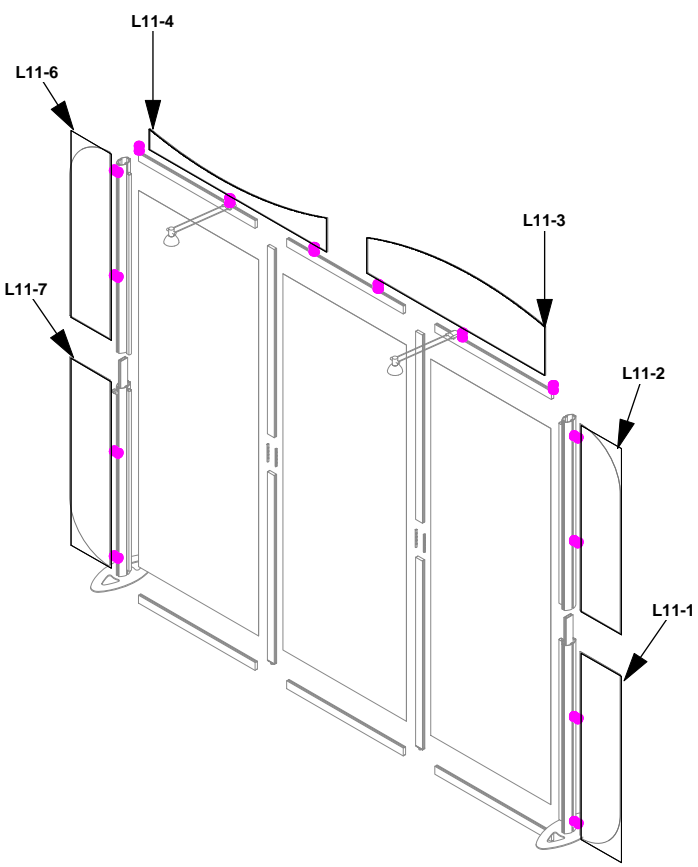
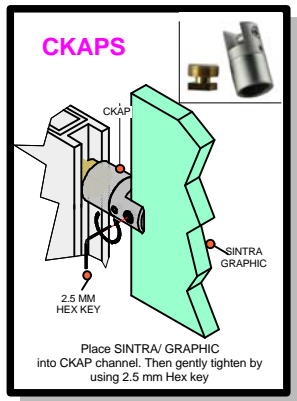
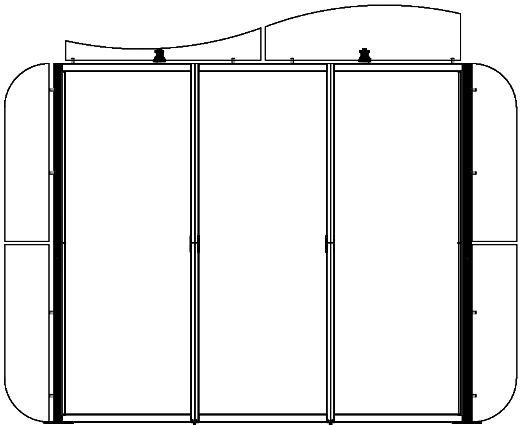
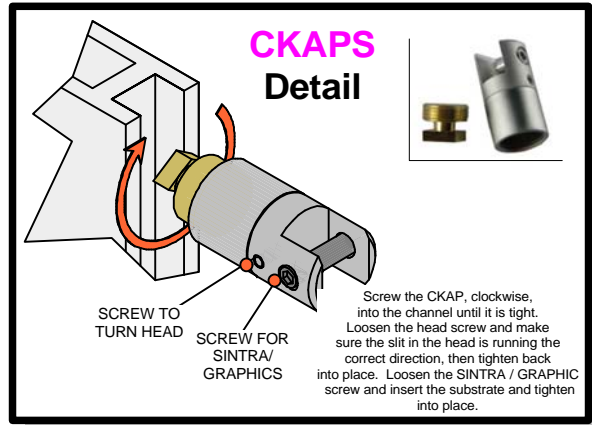
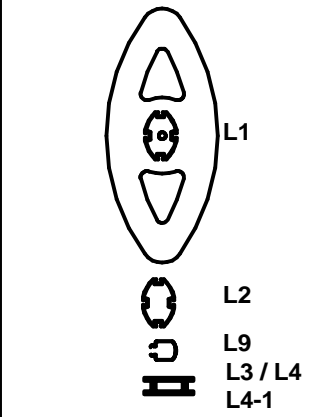

**LINEAR 25**

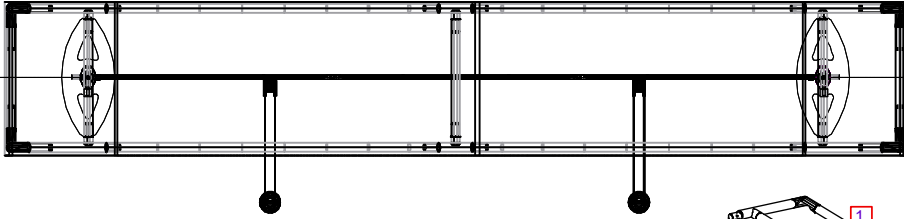

### Frame Assembly

Assemble frame as shown

#### PART LIST:

PER UNIT  
7 30MM DIA. TUBE SECTIONS

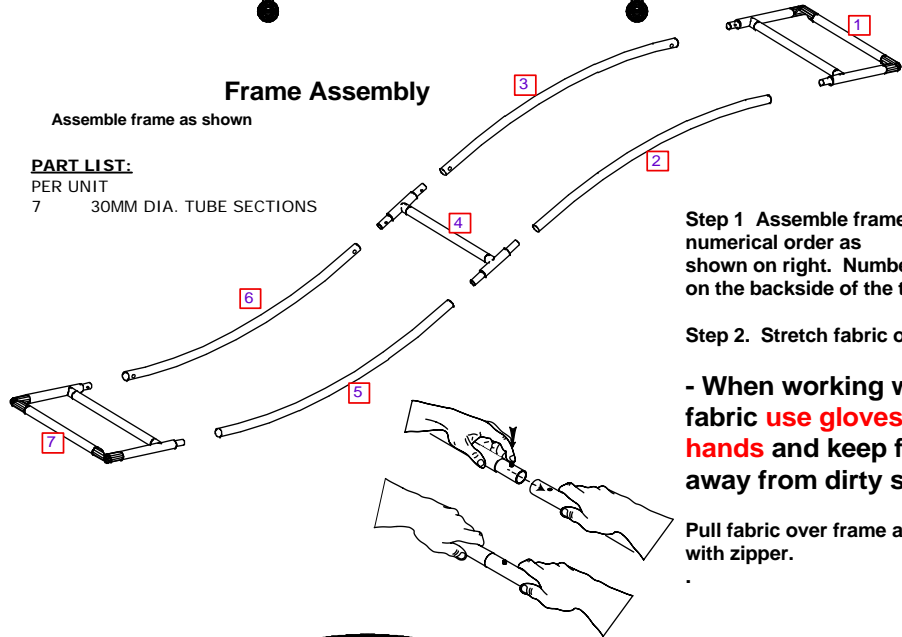

Step 1 Assemble frame in numerical order as shown on right. Numbers will be on the backside of the tube.

Step 2. Stretch fabric over frame.

- When working with fabric **use gloves or clean hands** and keep fabric away from dirty surfaces.

Pull fabric over frame and secure with zipper.

Code	#	Description
L13	1	LONG CANOPY CONNECTOR
L12	1	SHORT CANOPY CONNECTOR
WAVE CANOPY	1	WAVE CANOPY
CANOPY SCREW	2	CANOPY SCREW
CANOPY WASHER	2	CANOPY WASHER

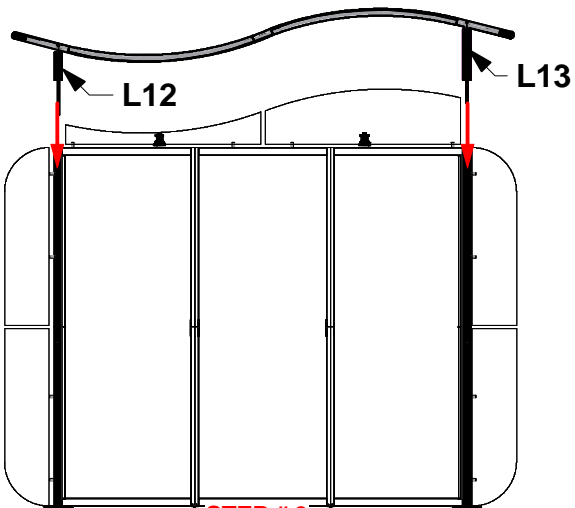
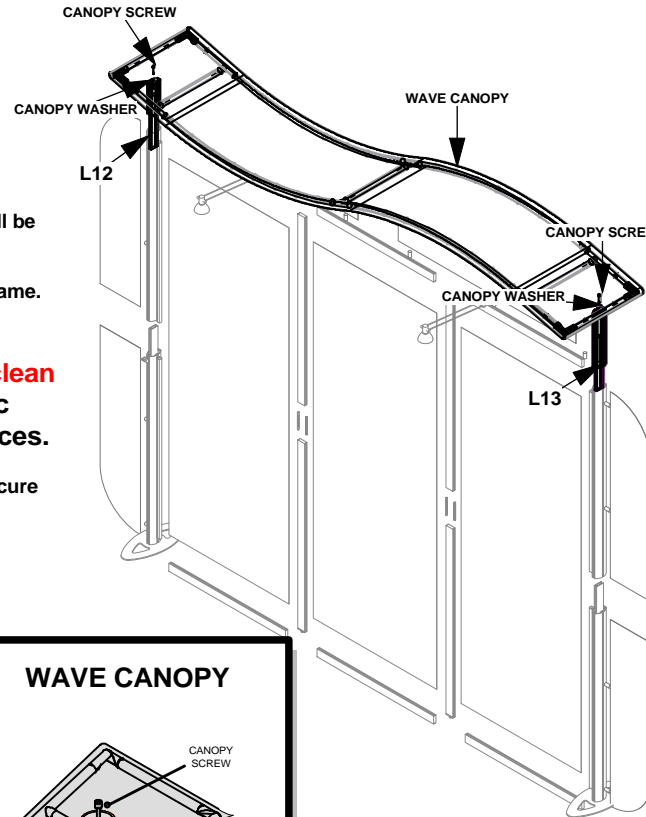

STEP # 3

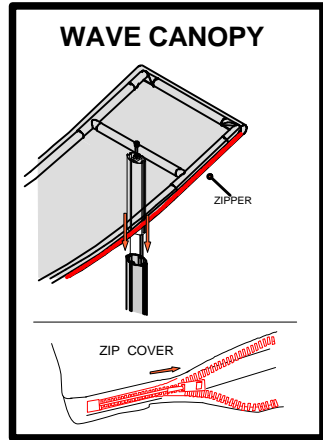

STEP # 3

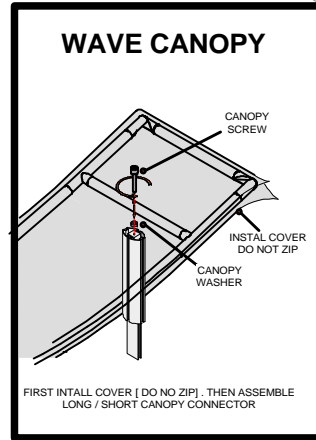

STEP #1

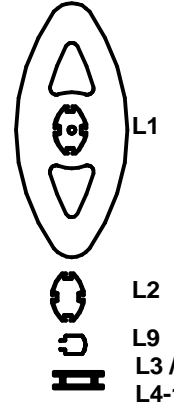

LINEAR 25

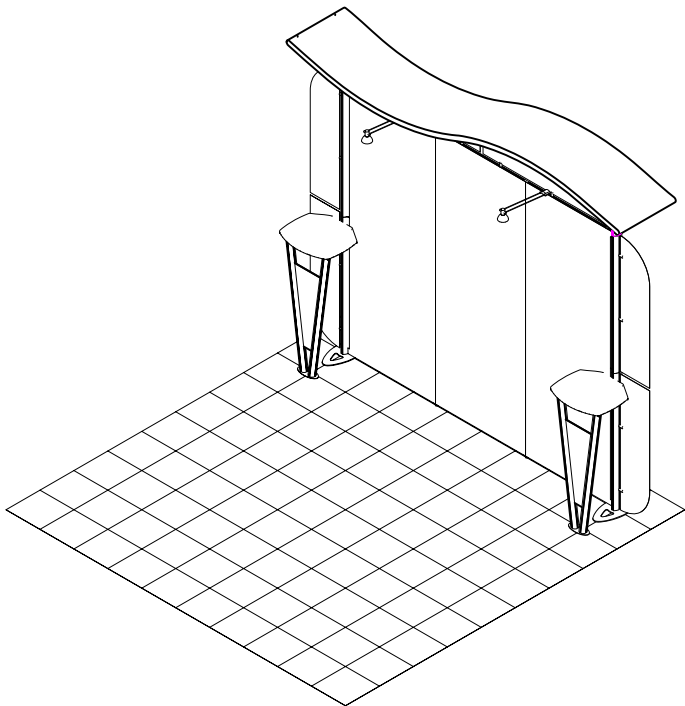
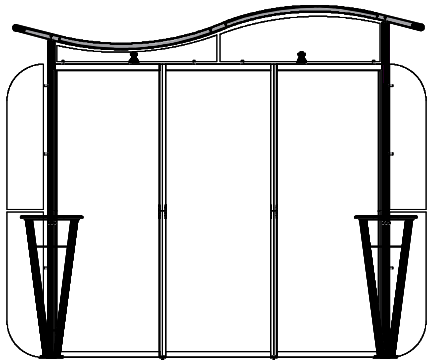
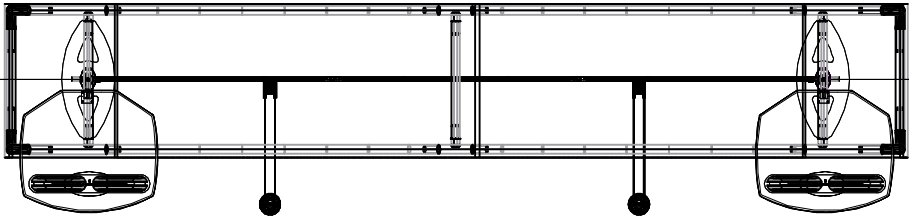

Code	#	Description
L15	2	V-LEG GRAPHIC
	2	
L16	2	TABLE TOP V-LEG
L14	2	V-LEG TABLE

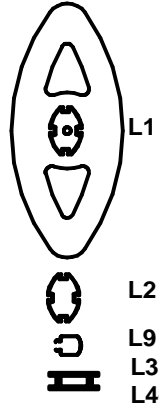
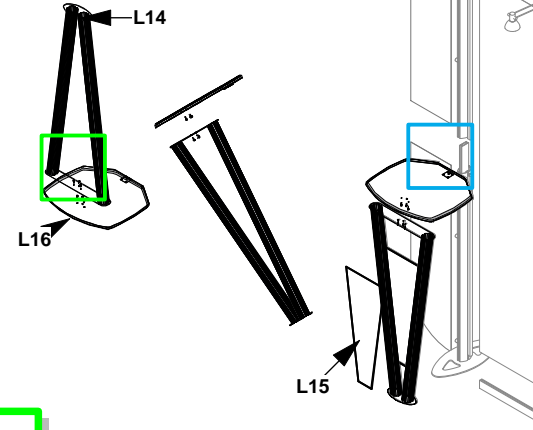

**LINEAR 25**

**TABLE TOP V LEG**

THUMBSCREWS

TABLE V-LEG

TABLE TOP

Turn Over TABLE TOP and gently tighten TABLE V-LEG in place.

**TABLE TOP DETAIL**

TABLE TOP

TOOL

BOTTOM UPRIGHT

CORNER LOCK

Attach TABLE TOP to bottom upright extrusion by locking CORNER LOCK.